

1.5V/2A Buck Converter and 5V Linear Charger in-One Solution for Lithium Battery

DESCRIPTION

The ETA6017 includes a 5V single cell Li+ battery linear charger and a 1.5V/2A buck synchronous converter.

The linear charger is fully integrated with constant current (CC) / constant voltage (CV) control module and a charge FET.

It also can drive a LED via output pin to indicate the charge status.

The integrated 1.5V output buck converter is capable of delivering 2A current at output.

ETA6017 is available in a QFN3x3-16 package.

FEATURES

- ◆ 4.2V/4.35V charge termination voltage
- ◆ Charge current programmable
- ◆ 1.5V/2A output power
- ◆ Up to 94% Efficiency for buck
- ◆ NTC thermistor input
- ◆ Thermal shutdown
- ◆ QFN3x3-16 Package

APPLICATIONS

- ◆ Lithium Battery

TYPICAL APPLICATION

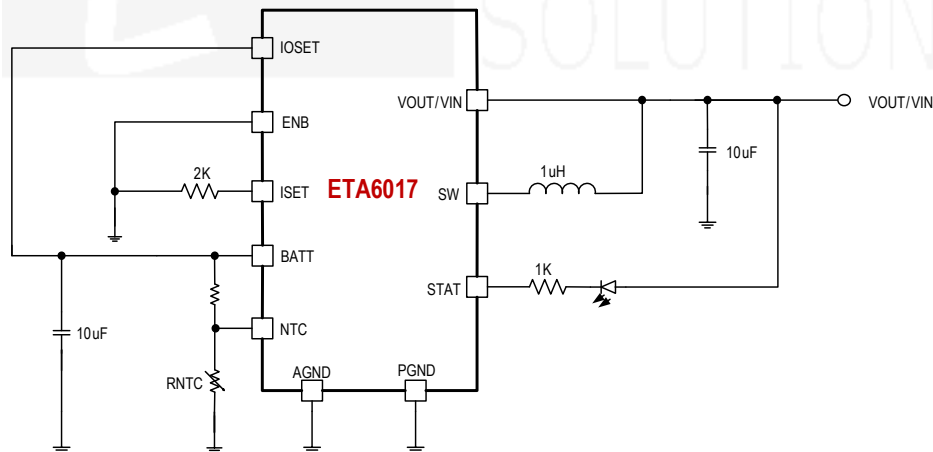

ORDERING

INFORMATION

PART No.	PACKAGE	TOP MARK	Pcs/Reel
ETA6017Q3Q	QFN3x3-16L	ETA6017 420 <u>YWWPL</u>	5000
ETA6017V435Q3Q	QFN3x3-16L	ETA6017 435 <u>YWWPL</u>	5000

PIN CONFIGURATION

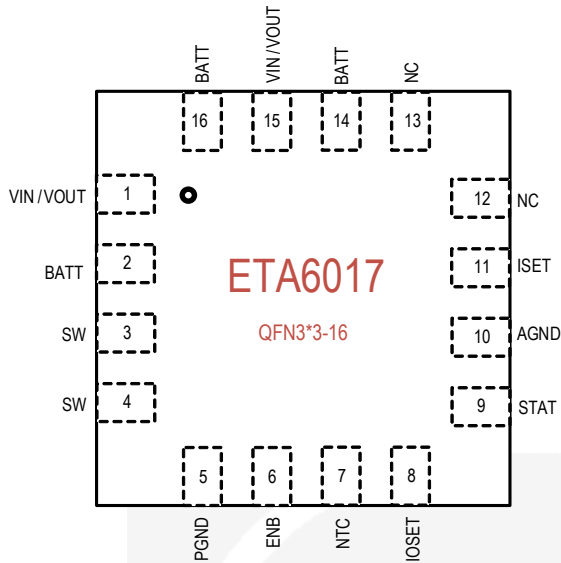

ABSOLUTE MAXIMUM RATINGS

(Note: Exceeding these limits may damage the device. Exposure to absolute maximum rating conditions for long periods may affect device reliability.)

ALL PIN Voltage.....	-0.3V to 6V
SW to ground current	Internally limited
Operating Temperature Range	-40°C to 85°C
Storage Temperature Range	-55°C to 150°C
Thermal Resistance θ_{JA} θ_{JC}	
QFN3x3-16.....	50.....12.....°C/W
Lead Temperature (Soldering 10sec)	260°C
ESD HBM (Human Body Mode)	2KV
ESD MM (Machine Mode)	200V
LATCHUP.....	200mA

ELECTRICAL CHARACTERISTICS

($V_{BAT}=3.8V$, $V_{in} = 5V$, unless otherwise specified. Typical values are at $T_A = 25^\circ C$.)

PARAMETER	CONDITIONS	MIN	TYP	MAX	UNITS
Linear Charger					
INPUT Range	VIN Voltage	3.85		5.5	V
VIN UVLO	Rising, Hys=200mV		3.85		V
VIN Discharging Threshold	VIN Voltage Charging transfer to Discharging			1.65	V
Input current when charging completed			2		mA
Battery CV voltage	$I_{BAT} = 0mA$, default	4.16	4.2	4.24	V
Charger Restart Threshold	From DONE to CC mode		-150		mV
Battery Pre-condition Voltage	V_{BAT} Rising Hys=180mV		2.7		V
Pre-Condition Charge Current			100		mA
CC Charge Current	$R_{ISET} = 2K\Omega$		500		mA
Termination Current Threshold	$R_{ISET} = 2K\Omega$		50		mA
Pre-condition Timer			120		min
Fast-Char Timer			600		min
Buck Converter					
VBATT Range		3.0	3.7	5.0	V
VBATT Low Batt detection threshold (V_L)	HYS=70mV		3.50		V
VBATT discharging disable threshold (V_D)	HYS=150mV		3.35		V

PARAMETER	CONDITIONS	MIN	TYP	MAX	UNITS
Output voltage (Vout)	$V_{BAT} > V_L$	1.45	1.5	1.55	V
	$V_D < V_{BAT} \leq V_L$	1.07	1.1	1.13	
	$V_{BAT} \leq V_D$		0		
VBATT Operating Current	$V_{BAT} > V_L$			90	μ A
	$V_D < V_{BAT} \leq V_L$			70	
	$V_{BAT} \leq V_D$			40	
Load Regulation			40		mV/A
Switching Frequency			3		MHz
HIGHSIDE Current limit	IOSET=High		2.0	2.6	A
	IOSET=Low		1.0	1.3	

NTC

NTC Threshold, Hot When Charging	Charger Suspended, HYS=1%		30		$\%V_{BAT}$
NTC Threshold, Cold When Charging	Charger Suspended. HYS=2%		76.5		$\%V_{BAT}$
NTC Threshold, Hot When Discharging	Output Suspended. HYS=1%		25		$\%V_{BAT}$
NTC Threshold, Cold When Discharging	Output Suspended. HYS=2%		75		$\%V_{BAT}$
NTC Threshold Hysteresis			1		$\%V_{BAT}$
NTC Disable Threshold			100		mV
NTC Input Leakage			0		μ A

ENB,IOSET PIN

ENB	High		1.2		V
	Low			0.4	V
IOSET	High		1.2		V
	Low			0.4	V

PIN DESCRIPTION

PIN #	NAME	DESCRIPTION
1,15	VIN/VOUT	Input or Output PIN, when in charge mode, it is VIN. when in discharge mode, it is VOUT. Bypass with a 10 μ F ceramic capacitor to GND
2,14,16	BATT	Connected to the battery positive terminal. Bypass with a 10uF ceramic capacitor to GND
3,4	SW	Inductor Connection. Connect an inductor Between SW and the OUT
5	PGND	Power GND
6	ENB	Enable PIN, ENB=0, enable this IC. ENB=1, disable this IC. Default it is low.
7	NTC	Battery Temperature Monitoring input pin. It sets the valid temperature operating range for battery charging and discharging

PIN #	NAME	DESCRIPTION
8	IOSET	HIGHSIDE Current limit select PIN.
9	STAT	drive a LED to indicate the charge status
10	AGND	Analog GND
11	ISET	Charge current program pin. The charge current is programmed by connecting a 1% resistor (RISET), between ISET, to GND pin. The charge current can be calculated using the following formula: $I_{BAT} = \frac{1}{R_{set}} \times 1000$
12,13	NC	NO Contact

TYPICAL CHARACTERISTICS

(Typical values are at $T_A = 25^\circ\text{C}$ unless otherwise specified.)

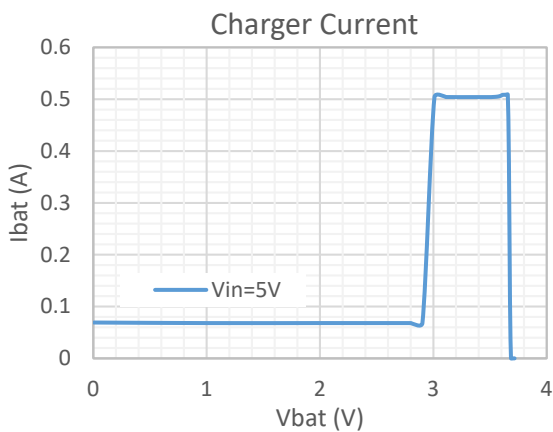
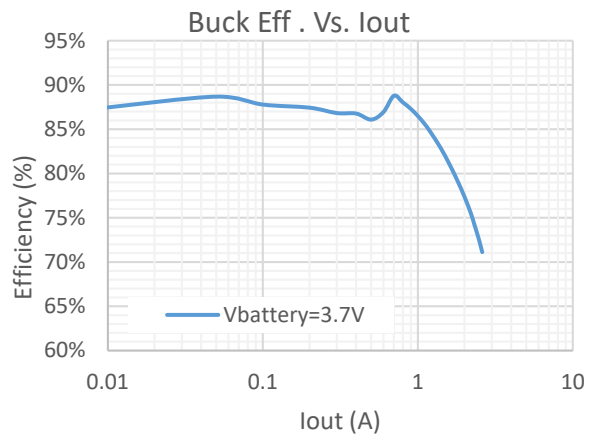
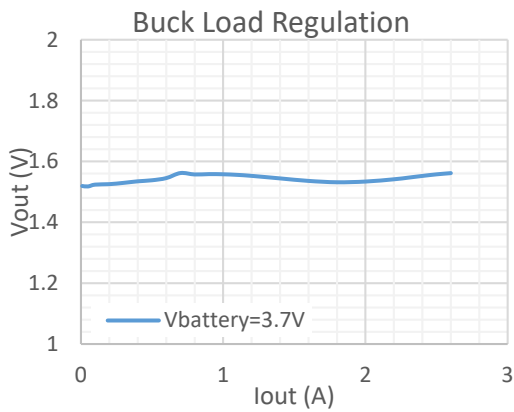

PACKAGE OUTLINE

Package: QFN3x3-16L

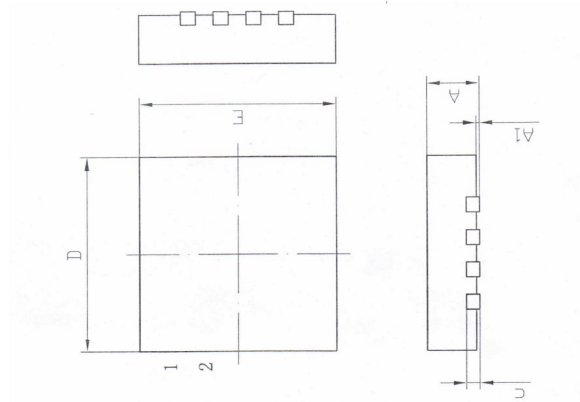

SYMBOL	MILLIMETER		
	MIN	NOM	MAX
A	0.70	0.75	0.80
A1	—	0.02	0.05
b	0.18	0.25	0.30
c	0.18	0.20	0.25
D	2.90	3.00	3.10
D2	1.55	1.65	1.75
e	0.50BSC		
Ne	1.50BSC		
Nd	1.50BSC		
E	2.90	3.00	3.10
E2	1.55	1.65	1.75
L	0.35	0.40	0.45
h	0.20	0.25	0.30
L/F载体尺寸 (mm)	75x75		

