

30V Input Standoff, 1A Fully Integrated Linear Charger for 1 Cell Li-ion Battery

DESCRIPTION

ETA4040 is a single cell, fully integrated constant current (CC)/constant voltage (CV) Li-ion battery charger. Its compact package with minimum external components requirement makes the ETA4040 ideal for portable applications. No external sense resistor or blocking diode is necessary for the ETA4040. Build-in thermal feedback mechanism regulates the charge current to control the die temperature during high power operation or at elevated ambient temperature. The ETA4040 has the function of pre-charge, which can charge the deeply discharged batteries by trickle. The fast charge current can be programmed by an external resistor. CV regulation mode is automatically enabled once the battery's charging curve reaches the constant voltage portion. The pre-charge current and the termination current threshold are programmed by an external resistor as well. The ETA4040 keeps monitoring the battery voltage and enables a new charge cycle once the voltage drops by 100mV below the CV value.

ETA4040 is in a DFN2X2-10 package.

FEATURES

- ◆ 30V Input Standoff Voltage
- ◆ 4.2V Charge Termination Voltage
- ◆ Charge Current Programmable, Up to 1A
- ◆ Pin Selectable USB 100mA or 500mA Maximum Input Current Limit
- ◆ Programmable Termination Current and Pre-charge Current Threshold
- ◆ Operation over JEITA Range via Battery NTC
- ◆ Fixed 10 hours Safety Timer
- ◆ Soft-start Limits in-rush Current
- ◆ DFN2X2-10 Package

APPLICATIONS

- ◆ E-cigarette
- ◆ Toys
- ◆ Wearable Devices
- ◆ Li-ion Battery Powered Devices

TYPICAL APPLICATION

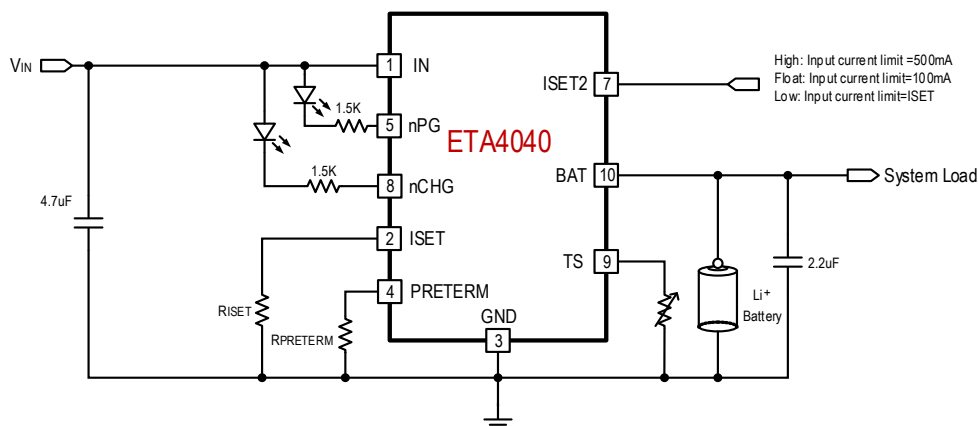

ORDERING INFORMATION

PART No.	PACKAGE	TOP MARK	Pcs/Reel
ETA4040D2K	DFN2X2-10	BEYW	3000

PIN CONFIGURATION

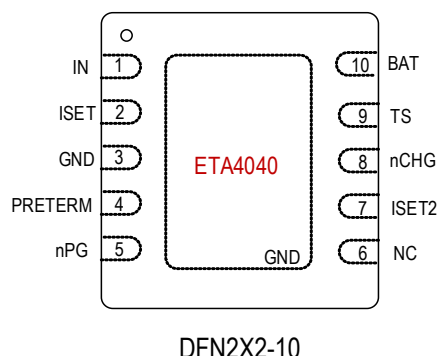

ABSOLUTE MAXIMUM RATINGS

(Note: Exceeding these limits may damage the device. Exposure to absolute maximum rating conditions for long periods may affect device reliability.)

IN Pin Voltage	-0.3V to 30V
BAT, nCHG, TS, nPG Pin Voltage	-0.3V to 16V
All other pin Voltage.....	-0.3V to 6V
Operating Temperature Range.....	-40°C to 85°C
Storage Temperature Range	-55°C to 150°C
Thermal Resistance θ_{JC} θ_{JA}	
DFN2X2-10	12.....62..... °C/W
Lead Temperature (Soldering, 10sec)	260°C
ESD HBM (Human Body Mode).....	2KV
ESD CDM (Charged Device Mode).....	1KV

ELECTRICAL CHARACTERISTICS

($V_{IN} = 5V$, unless otherwise specified. Typical values are at $T_A = 25^\circ C$.)

PARAMETER	CONDITIONS	MIN	TYP	MAX	UNITS
Input Standoff Voltage		30			V
V_{IN} Under-voltage Lockout Threshold	V_{IN} from Low to High	3.1	3.3	3.5	V
V_{IN} Under-voltage Lockout Hysteresis			0.2		V
$V_{IN} - V_{BAT}$ Lockout Threshold Voltage	V_{IN} from Low to High	50	150	220	mV
	V_{IN} from High to Low	20	70	170	
Input Over-Voltage Protection Voltage	V_{IN} rising, hys = 0.1V	6.4	6.65	6.9	V
Input Voltage Range for Charging		4.5		6.5	V
V_{INDPM} Voltage Threshold	USB Mode (ISET2 Floating, High)		4.4		V
	Adaptor Mode (ISET2 Low)		4.3		V
Input Current Limit	ISET2 Floating		100		mA
	ISET2 High		500		mA
Maximum Charge Current	ISET2=GND		1.2		A
BAT Pin Current	Sleep Mode, $V_{IN} = 0V$			1	μA
	Charging Terminated, $V_{BAT} = 4.5V$		6	10	μA
Input Standby Current	$V_{IN}=5V$, TS = Low		100		μA
Input Active Supply Current	Charging Terminated, $V_{IN}=5V$, $V_{BAT}=4.5V$		0.3	0.5	mA
Power FET "ON" Resistance (Between IN and BAT)			0.6		Ω
Soft-Start Time			40		ms
Battery Regulation Output Voltage	$R_{ISET} = 1K$, $I_{BAT} = 40mA$	4.16	4.2	4.24	V
Battery Hot Regulation Output Voltage	$R_{ISET} = 1K$, $I_{BAT} = 40mA$		4.06		V

PARAMETER	CONDITIONS	MIN	TYP	MAX	UNITS
Charge Current Range	$R_{ISET} = 0.54K$ to $10.8K$	50		1000	mA
Dropout Voltage	$V_{BAT} = 4.15V$, $R_{ISET} = 0.54K$, Adjust V_{IN} until $I_{BAT} = 0.5A$		320		mV
Charge Current Accuracy	$R_{ISET} = 0.83K$	0.61	0.65	0.69	A
Pre-charge Threshold Voltage	V_{BAT} Rising		2.6		V
Pre-charge Threshold Voltage Hysteresis	V_{BAT} Falling		100		mV
Pre-charge Current	$R_{PRETERM} = 2K$, $R_{ISET} = 1K$	14	20	26	% I_{CHG}
Termination Current	$R_{PRETERM} = 2K$, $R_{ISET} = 1K$	6	10	14	% I_{CHG}
PRETERM Bias Current			75		μA
Recharge BAT Threshold Voltage	Normal	50	100	150	mV
	Hot temp		110		mV
NTC Bias Current	$V_{TS} = 0.3V$		50		μA
10K NTC Bias Current when Charging is Disabled	$V_{TS} = 0V$		30		μA
I_{NTC} is Reduced Prior to Entering TTDM to Keep Cold Thermistor from Entering TTDM	$V_{TS} = 1.525V$		5		μA
Termination and Timer Disable Mode Threshold–Enter			1600		mV
Hysteresis Exiting TTDM			100		mV
TS Voltage where I_{NTC} is Reduced to Keep Thermistor from Entering TTDM			1475		mV
Low Temperature CHG Pending ($0^{\circ}C$)			1230		mV
Hysteresis at $0^{\circ}C$			86		mV
Low Temperature, Half Charge ($10^{\circ}C$)			790		mV
Hysteresis at $10^{\circ}C$			35		mV
High Temperature at $4.1V$ ($45^{\circ}C$)			278		mV
Hysteresis at $45^{\circ}C$			11		mV
High Temperature Disable ($60^{\circ}C$)			178		mV
Hysteresis at $60^{\circ}C$			11		mV
TS Voltage Threshold (disable charge)	Falling		90		mV
TS Voltage HYS (disable charge)	Falling		10		mV
Junction Temperature in Constant Temperature Mode			110		$^{\circ}C$
Thermal Shutdown Temperature			155		$^{\circ}C$
Thermal Shutdown Hysteresis			25		$^{\circ}C$
ISET2 Logic Low Input				0.4	V
ISET2 Logic High Input		1.4			V
ISET2 Floating Voltage			0.9		V
nPG/nCHG Pin Weak Pull-Down Current	$V_{nPG} = V_{nCHG} = 5V$			1	μA
nPG/nCHG Pin Output Low Voltage	I_{nPG} or $I_{nCHG} = 5mA$			0.4	V

PARAMETER	CONDITIONS	MIN	TYP	MAX	UNITS
Pre-charge Safety Timer			1800		s
Total Safety Timer			36000		s

PIN DESCRIPTION

PIN#	NAME	DESCRIPTION
1	IN	Input Power Pin. Bypass with at least a 4.7uF capacitor to GND.
2	ISET	<p>Fast Charge Current Setting Pin. Program, Monitor the charge current and Shutdown. This pin set to 1.5V in constant-current mode. The fast charge current can be calculated using the following formula:</p> $I_{BAT} = \frac{1}{R_{ISET}} \times 540$ <p>The ISET pin can also be used to switch the charger to shutdown mode by disconnecting the program resistor from ground.</p>
3/Thermal Pad	GND	Ground
4	PRETERM	<p>Program the termination current threshold (5 to 50% of I_{CHG} which is set by ISET pin) and set the pre-charge current to twice the termination current. Expected range of programming resistor is from 1K to 10K. (e.g. When $R_{PRETERM}=2K$, $I_{TERM}=I_{CHG}/10$ and $I_{PRECHG}=I_{CHG}/5$)</p>
5	nPG	Low (FET on) indicates that the input voltage is above UVLO and the battery voltage.
6	NC	Not Connected
7	ISET2	<p>Program the Input Current Limit for the USB or Adaptor source: Pull this pin high, $I_{INLIM}=500mA$; Float this pin, $I_{INLIM} = 100mA$; Pull this pin low, $I_{INLIM} = ISET$</p>
8	nCHG	Low (FET on) indicates charging and Open Drain (FET off) indicates no charging or charge completed
9	TS	<p>Temperature Sense Pin. The value of NTC thermistor is 10K at 25 °C. Floating TS pin or pulling it high drives the IC to enter TTDM, which disables TS monitoring, timer and termination. Pulling TS low disables the IC. If the NTC function is not needed, connect this pin to GND with an external 10K resistor. Connecting a 250K resistor from TS to GND can prevent IC from entering TTDM when removing the battery with thermistor.</p>
10	BAT	Battery Connection Pin. This pin provides charge current to the battery and regulates the final float voltage to 4.2V which is set by an internal precision resistor divider. Connect a 2.2uF capacitor from this pin to GND.

FUNCTION BLOCK DIAGRAM

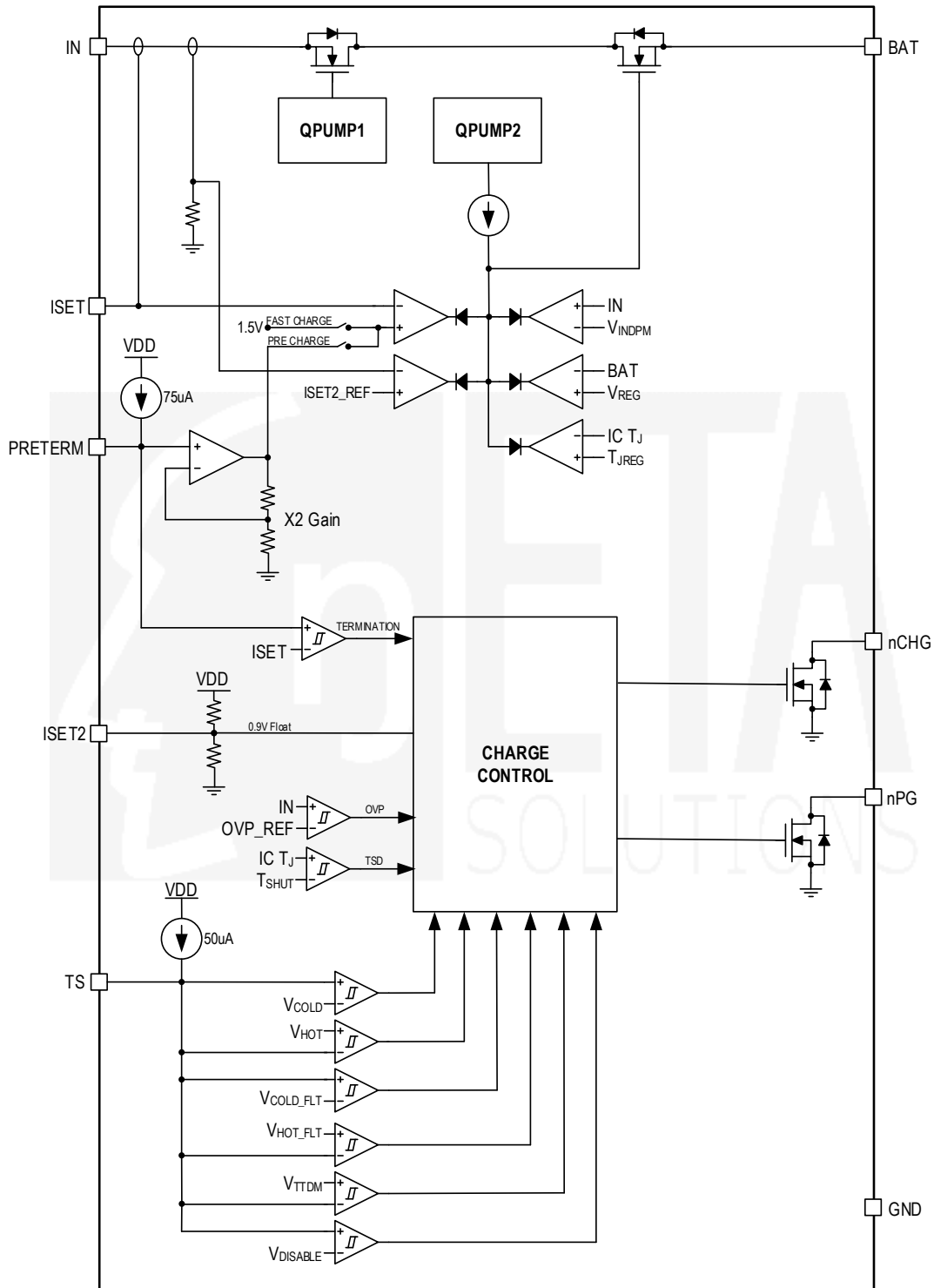

TYPICAL CHARACTERISTICS

(Typical values are at $T_A = 25^\circ\text{C}$ unless otherwise specified.)

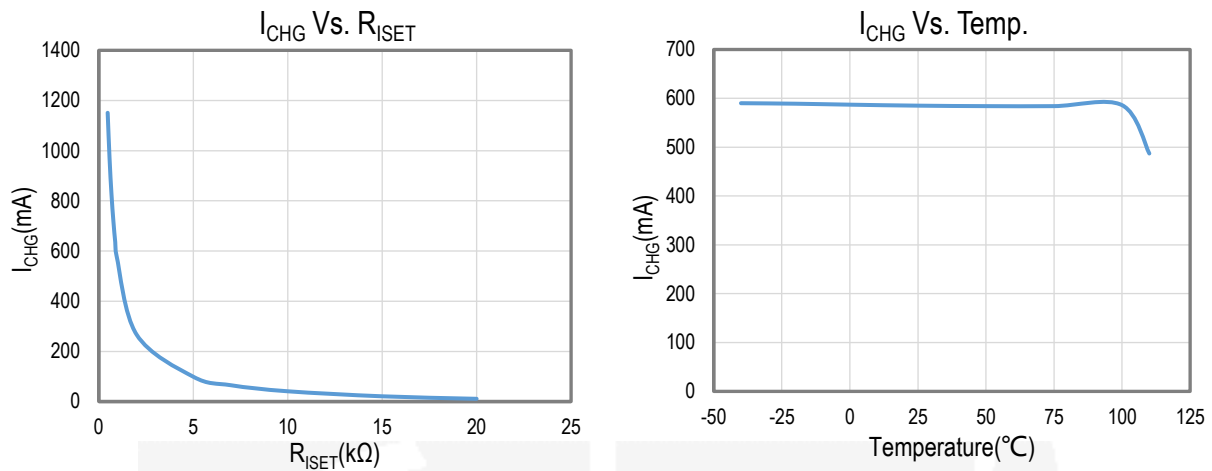

FUNCTIONAL DESCRIPTIONS

ETA4040 is a single cell, fully integrated Li-ion battery charger.

The charger has three phases of charging:

- Pre-charge to recover a fully discharged battery
- Fast charge constant current to supply the buck charge safely
- Voltage regulation to safely reach full capacity

The charger is very flexible, allowing programming of the fast-charge current and pre-charge/termination current. This charger is designed to work with a USB connection or Adaptor (DC out). The charger also checks to see if a battery is present.

The charger also comes with a full set of safety features:

- JEITA Temperature Standard
- Input Over Voltage Protection
- V_{INDPM}
- Safety Timers
- ISET short protection

If the battery voltage is below the pre-charge voltage threshold, the battery is considered discharged and a pre-conditioning cycle begins. The amount of pre-charge current can be programmed using the PRETERM pin which programs a percent of fast charge current (10% to 100%) as the pre-charge current. This feature is useful when the system load is connected across the battery "stealing" the battery current. The pre-charge current can be set higher to account for the system loading while allowing the battery to be properly conditioned. The PRETERM pins a dual function pin which sets the pre-charge current level and the termination threshold level. The termination "current threshold" is always half of the pre-charge programmed current level.

Once the battery voltage has charged by the pre-charge voltage threshold, fast charge is initiated and the fast charge current is applied. The fast charge constant current is programmed by the ISET pin. The constant current provides the bulk of the charge. Power dissipation in the IC is greatest in fast charge with a lower battery voltage. If the IC reaches 125°C the IC enters thermal regulation, slows the timer clock by half and reduce the charge current as

needed to keep the temperature from rising any further.

Once the cell has charged to the regulation voltage, the voltage loop takes control and holds the battery at the regulation voltage until the current tapers to the termination threshold. The termination can be disabled if desired. The nCHG pin is low (LED on) during the first charge cycle only, and turns off once the termination threshold is reached. regardless if charge loop start to recharge or re-enter EOC, LED will keep off status.

Power-Down or Undervoltage Lockout (UVLO)

ETA4040 is in power down mode if the IN pin voltage is less than UVLO. The part is considered “dead” and all the pins are high impedance. Once the IN voltage rises above the UVLO threshold the IC will enter Sleep Mode or Active mode depending on the battery voltage.

Power Up

The IC is alive after the IN voltage ramps above UVLO (see Sleep Mode), resets all logic and timers, and starts to perform many of the continuous monitoring routines. Typically the input voltage quickly rises through the UVLO and sleep states where the IC declares power good, sets the input current limit threshold base on the ISET2 pin, starts the safety timer and enables the nCHG pin

Sleep Mode

If the IN pin voltage is between $V_{BAT}+V_{SLEEP}$ and UVLO, the charge current is disabled, the safety timer counting stops (not reset) and the nPG and nCHG pins are high impedance. As the input voltage rises and the charger exits sleep mode, the nPG pin goes low, the safety timer continues to count, charge is enabled and the nCHG pin returns to its previous state

New Charge Cycle

A new charge cycle is started when any of these events occur:

- A valid power source is applied
- The chip is enabled/disabled using TS pin
- Exit of termination/Timer Disable Mode (TTDM)
- Detection of batter insertion
- BAT voltage drops below the VRCH threshold.

The nCHG signal is active only during the first charge cycle. Exiting TTDM or the BAT voltage falling below VRCH will not activate the nCHG signal if it is already in the open-drain (off) state.

Over Voltage Protection (OVP)

If the input source applies an overvoltage, the pass FET will turn off. The timer ends and the nCHG and nPG pins go to a high impedance state. Once the overvoltage returns to a normal voltage, the nPG pin goes low, timer continues, charge continues and the nCHG pin goes low after a 25 ms deglitch.

Power Good Indication (nPG)

After application of a 5V source, the input voltage rises above the UVLO and sleep thresholds ($V_{IN}>V_{BAT}+V_{SLEEP}$), but is less than OVP ($V_{IN}<V_{OVP}$), then the nPG FET turns on and provides a low impedance path to ground.

VIN POWER GOOD STATE	nPG FET
UVLO	OFF
SLEEP	
OVP	
NORMAL INPUT	ON
PG is independent of chip disable	

nCHG Termination Indication (nCHG)

The charge pin has an internal open drain FET which is on (pulls down GND) during the first charge only (independent of TTDM) and is turned off once the battery reaches voltage regulation and the charge current tapers to the termination threshold set by the PRETERM resistor. The charge pin is high impedance in sleep mode and OVP (if nPG is high impedance) and return to its previous state once the condition is removed. Cycling input power, pulling the TS pin low and releasing or entering pre-charge mode causes the nCHG pin to go reset (go low if power is good and a discharged battery is attached) and is considered the start of a first charge.

CHARGING STATE	nCHG FET
First charge after VIN applied	ON
Refresh Charge	OFF
OVP	
SLEEP	
TEMP FAULT	ON for 1st Charge

VINDPM

The VINDPM feature is used to detect an input source voltage that is folding back (voltage drooping), reaching its current limit due to excessive load. When the input voltage drops to the VINDPM threshold the internal pass FET starts to reduce the current until there is no further drop in voltage at the input. This would prevent a source with voltage less than VINDPM to power the battery. This works well with current limited adaptors and USB ports as long as the nominal voltage is above 4.3V and 4.4V respectively. This is an added safety feature that helps protect the source from excessive loads.

Programming Charge Current

The charge current is programmable by setting the value of a precision resistor connected from the ISET pin to ground. The charge current out of the BAT pin can be determined at any time by monitoring the ISET pin voltage using the following equation:

$$I_{BAT} = \frac{1}{R_{ISET}} \times 540$$

Pre-charge and Charge Termination

PRETERM pin is used to program both the pre-charge current and the termination current threshold. The pre-charge current level is a factor of two higher than the termination current level. The termination can be set between 5 and 50% of the programmed output current level set by ISET. If left floating the termination and pre-charge are set internally at 10/20% respectively. The pre-charge current and the termination current are set following the below equation.

$$I_{\text{Pre-charge}} = \frac{R_{\text{PRETERM}}}{1K} \times 0.1 \times I_{\text{CHG}}$$

$$I_{\text{EOC}} = \frac{R_{\text{PRETERM}}}{1K} \times 0.05 \times I_{\text{CHG}}$$

ISET2 and IINDPM

ISET2 is a 3-state input and programs the Input Current Limit/Regulation Threshold. A low level will program a regulated fast charge current via the ISET resistor and is the maximum allowed input/output current for any ISET2 setting, Float will program a 100mA Input Current limit and High will program a 500 mA Input Current limit.

Battery Temperature Monitoring

ETA4040's TS function for the device is designed to follow the new JEITA temperature standard for Li-Ion and Li-Pol batteries. There are now four thresholds, 60°C, 45°C, 10°C, and 0°C. Normal operation occurs between 10°C and 45°C. If between 0°C and 10°C the charge current level is cut in half and if between 45°C and 60°C the regulation voltage is reduced to 4.06V

The TS feature is implemented using an internal 50uA current source to bias the thermistor (designed for use with a 10k NTC $\beta = 3370$ (SEMITEC 103AT-2 or Mitsubishi TH05-3H103F) connected from the TS terminal to GND. If this feature is not needed, a fixed 10 k can be placed between TS and GND to allow normal operation. This may be done if the host is monitoring the thermistor and then the host would determine when to pull the TS terminal low to disable charge.

The TS terminal has two additional features, when the TS terminal is pulled low or floated/driven high. A low disables charge and a high puts charger in TTDM. Above 60° C or below 0° C, the charge is disable. Once the thermistor reaches -10° C, the TS current folds back to keep a cold thermistor (between -10° C and -50° C) from placing the IC in the TTDM mode. If the TS terminal is pulled low into disable mode, the current is reduced to 30uA.

Termination and Timer Disable Mode (TTDM) - TS Terminal High

The battery charger is in TTDM when the TS terminal goes high from removing thermistor (removing battery pack/floating the TS terminal) or by pulling the TS terminal up to the TTDM threshold.

When entering TTDM, the 10 hour safety timer is held in reset and termination is disabled. A battery detect routine is run to see if the battery was removed or not. If the battery was removed then the nCHG terminal will go to its high impedance state if not already there.

The charging profile does not change (still has pre-charge, fast-charge constant current and constant voltage modes). This implies the battery is still charged safely and the current is allowed to taper to zero.

If TTDM is not desired upon removing the battery with the thermistor, one can add a 237-k resistor between TS and GND to disable TTDM. This keeps the current source from driving the TS terminal into TTDM. This creates 0.1°C error at hot and a 3°C error at cold.

Safety Timer

The pre-charge timer is set to 30 minutes. The pre-charge current can be programmed to off-set any system load, making sure that the 30 minutes is adequate. The fast charge timer is fixed at 10 hours and can be increased real time by going into thermal regulation, V_{INDPM} or if in USB Input current limit. The timer clock slows by a factor of 2, resulting in a clock that counts half as fast when in these modes. If either the 30 minutes or ten hours timer times out, the charging is terminated and the nCHG terminal goes high impedance if not already in that state. The timer

is reset by disabling the IC, cycling power or going into and out of TTDM.

Termination and Recharge

Once the BAT terminal goes above VRCH, (reaches voltage regulation) and the current tapers down to the termination threshold, the nCHG terminal goes high impedance and a battery detect routine is run to determine if the battery was removed or the battery is full. If the battery is present, the charge current will terminate. If the battery was removed along with the thermistor, then the TS terminal is driven high and the charge enters TTDM. If the battery was removed and the TS terminal is held in the active region, then the battery detect routine will continue until a battery is inserted.

After termination, if the BAT terminal voltage drops to VRCH (100mV below regulation) then a new charge is initiated, but the nCHG terminal remains at a high impedance (off).

Battery Detect Routine

The battery detect routine should check for a missing battery while keeping the BAT terminal at a useable voltage. Whenever the battery is missing the nCHG terminal should be high impedance. The battery detect routine is run when entering and exiting TTDM to verify if battery is present. On power-up, if battery voltage is greater than VRCH threshold, a battery detect routine is run to determine if a battery is present. The battery detect routine is disabled while the IC has a TS fault.

PACKAGE OUTLINE

Package: DFN2X2-10

From assembly house 1:

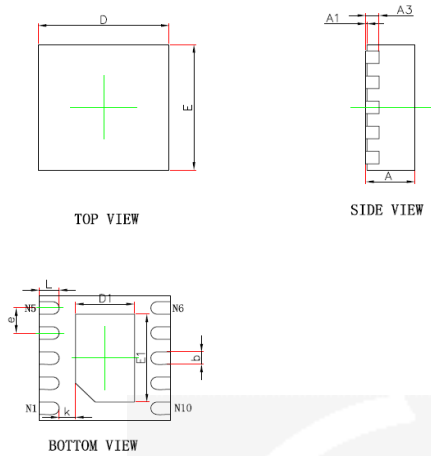

Symbol	Dimensions In Millimeters		Dimensions In Inches	
	Min.	Max.	Min.	Max.
A	0.700	0.800	0.028	0.031
A1	0.000	0.050	0.000	0.002
A3	0.203REF.		0.008REF.	
D	1.900	2.100	0.075	0.083
E	1.900	2.100	0.075	0.083
D1	0.800	1.000	0.031	0.039
E1	1.300	1.500	0.051	0.059
k	0.250 REF.		0.010REF.	
b	0.150	0.250	0.006	0.010
e	0.400BSC.		0.016BSC.	
L	0.224	0.376	0.009	0.015

From assembly house 2:

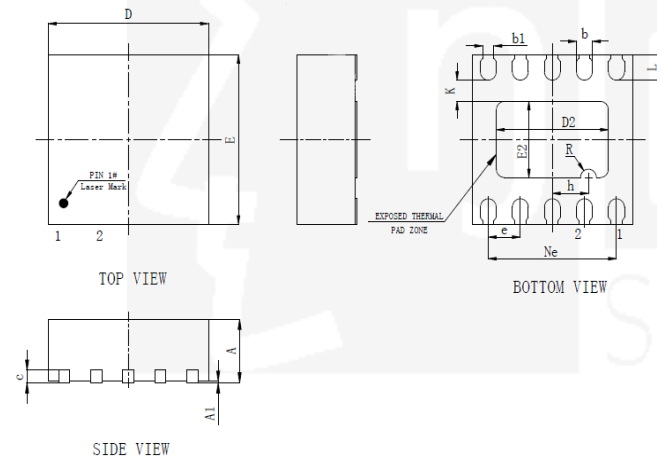

SYMBOL	MILLIMETER		
	MIN	NOM	MAX
A	0.70	0.75	0.80
	0.80	0.85	0.90
A1	0	0.02	0.05
b	0.15	0.20	0.25
b1	0.09	0.14	0.19
c	0.15	0.20	0.25
D	1.90	2.00	2.10
D2	1.30	1.40	1.50
e	0.40BSC		
Ne	1.60BSC		
E	1.90	2.00	2.10
E2	0.80	0.90	1.00
L	0.25	0.30	0.35
h	0.40	0.45	0.50
R	0.05	0.10	0.15
K	0.20	0.25	0.30

From assembly house 3:

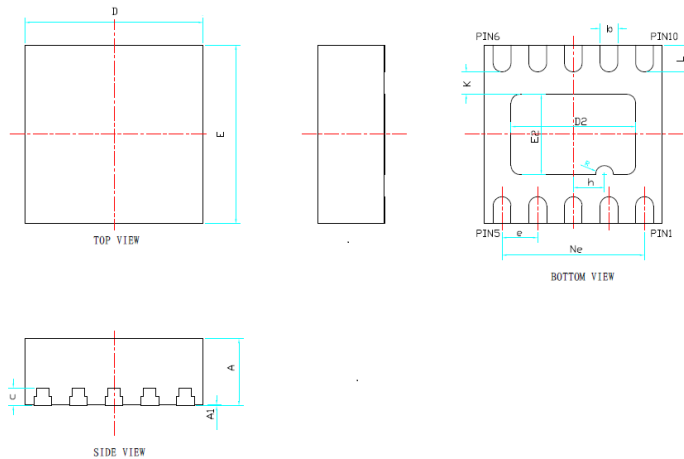

SYMBOL	MILLIMETER		
	MIN	NOM	MAX
A	0.70	0.75	0.80
A1	0	0.02	0.05
b	0.15	0.20	0.25
c	0.203REF		
D	1.90	2.00	2.10
D2	1.30	1.40	1.50
e	0.40BSC		
Ne	1.60BSC		
E	1.90	2.00	2.10
E2	0.80	0.90	1.00
L	0.25	0.30	0.35
h	0.30	0.35	0.40
R	0.05	0.10	0.15
K	0.20	0.25	0.30

TAPE AND REEL INFORMATION

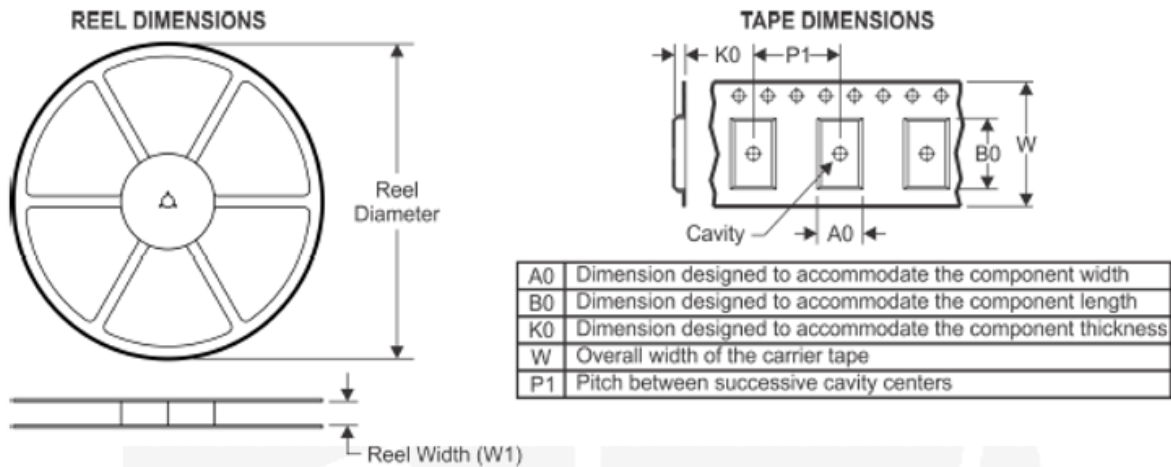

QUADRANT ASSIGNMENTS FOR PIN 1 ORIENTATION IN TAPE

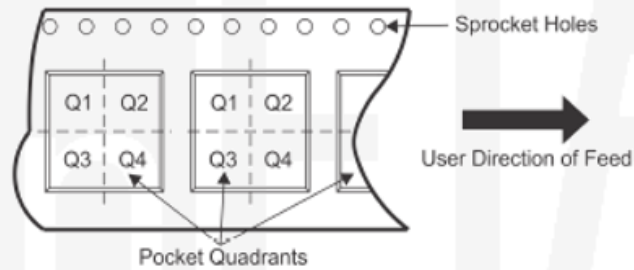

Device	Package Type	Pins	SPQ	Reel Diameter (mm)	Reel Width W1 (mm)	A0 (mm)	B0 (mm)	K0 (mm)	P1 (mm)	W (mm)	Pin1 Quadrant
ETA4040D2K	DFN2x2-10	10	3000	180	9.5	2.3	2.3	1.1	4	8	Q1