

18V, 2.5A, I²C Controlled Output Synchronous Step-Down Converter

DESCRIPTION

The ETA1459 is a wide input range, high-efficiency, DC-to-DC step-down switching regulator, capable of delivering up to 2.5A of output current. Its output can be dynamically controlled by I²C interface. Current mode PWM control allows the use of small external components, such as ceramic input and output caps, as well as small inductors, while still providing low output ripples. On top of the integrated internal synchronous rectifier that eliminates external Schottky diode, ETA1459 also employs a proprietary control scheme that switches the device into a power save mode during light load, thereby extending the range of high efficiency operation. Therefore, ETA1459 is a much superior solution in comparison to other competitions in terms of efficiency and cost. Cycle-by-cycle current limit provides output short-circuit protection and an input OVP function guards ETA1459 against possible input voltage surge. Overall, ETA1459 is a highly efficient and robust solution for DC-DC step-down applications that requires wide input ranges. ETA1459 is housed in a ESOP8 Package.

FEATURES

- I²C Dynamic Output Control
- Wide Input Operating Range from 4.2V to 18V
- High Efficiency:
 - Up to 90% at Light Load
 - Up to 95% at Heavy Load
- Capable of Delivering 2.5A
- Input OVP at 20V
- No External Schottky Diode Needed
- Thermal shutdown and UVLO

APPLICATIONS

- Smart TVs, Smart Set Top Box
- Tablet computer, MID

ORDERING INFORMATION

PART	PACKAGE PIN	TOP MARK
ETA1459E8A	ESOP8	ETA1459-Product Number YWWPL-Date Code

TYPICAL APPLICATION

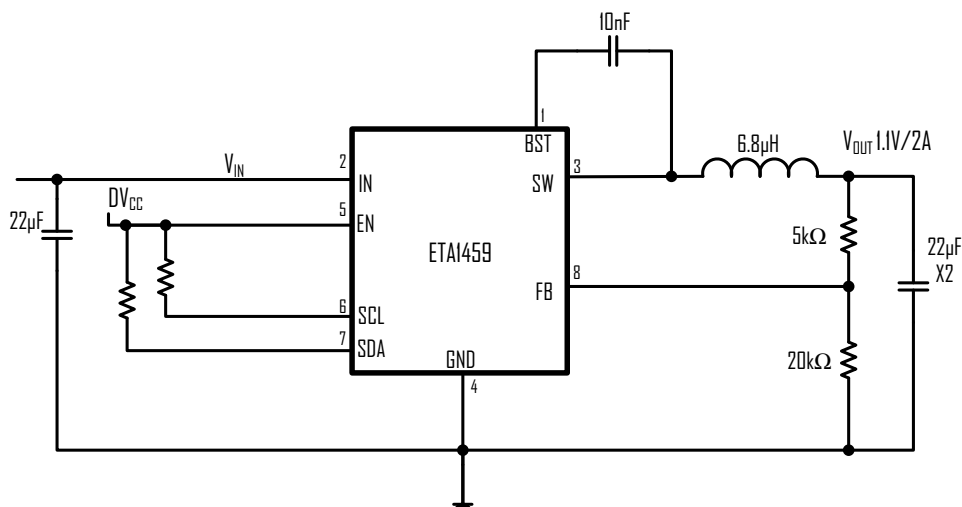

PIN CONFIGURATION

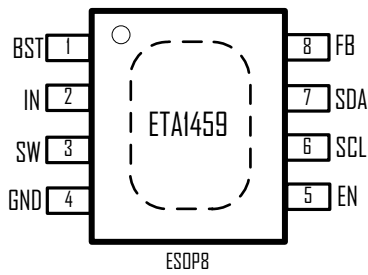

ABSOLUTE MAXIMUM RATINGS

(Note: Exceeding these limits may damage the device. Exposure to absolute maximum rating conditions for long periods may affect device reliability.)

IN Voltage.....	-0.3V to 20V
SW Voltage.....	-0.3V to VIN+0.3V
BST Voltage.....	-0.3V to SW+6V
Other Voltage.....	-0.3V to 6V
SW to ground current	Internally limited
Operating Temperature Range	-40°C to 85°C
Storage Temperature Range	-55°C to 150°C

ELECTRICAL CHARACTERISTICS

(VIN = 12V, unless otherwise specified. Typical values are at TA = 25°C.)

PARAMETER	CONDITIONS	MIN	TYP	MAX	UNITS
Input Voltage Range		4.2		18	V
Input UVLO	Rising, Hysteresis=200mV		3.6		V
Input OVP	Rising, Hysteresis=900mV	18.5	20	22	V
Input Supply Current	No Switching		750		µA
Input Shutdown Current				10	µA
Thermal Shutdown	Rising, Hysteresis=40 °C		156		°C
EN Input High Voltage		1.2	1.5	1.8	V
EN Input Current				1	µA
FB Feedback Voltage	000000		0.696		V
	010111		0.880		V
	111111		1.200		V
FB Short circuit foldback threshold			50		%*VREF
FB Input Current			10		nA
Load Regulation			0.5		%/A
Line Regulation	VIN =10to 12V		0.04		%/V
Switching Frequency			500		KHz
Maximum Duty Cycle			90		%
High Side NMOS Switch On Resistance	ISW =500mA		100		mΩ
Low Side NMOS Switch On Resistance	ISW =500mA		100		mΩ
High Side NMOS Switch Current Limit		3			A
Short Circuit Hiccup mode off time			20		ms

I2C Control

SCL clock frequency			400		KHz
SDA Setup time			100		ns
SDA Hold time			50		ns
Input High Voltage		1.5			V
Input Low Voltage				0.5	V

PIN DESCRIPTION

PIN #	NAME	DESCRIPTION
1	BST	Bootstrap pin. Connect a 10nF capacitor from this pin to SW
2	IN	Supply Voltage. Bypass with a 22µF ceramic capacitor to GND
3	SW	Inductor Connection. Connect an inductor Between SW and the regulator output.
4	GND	Ground
5	EN	Enable pin for the IC. Drive this pin to high to enable the part, low to disable.
6	SCL	I ² C clock input pin
7	SDA	I ² C data input pin
8	FB	Feedback Input. Connect an external resistor divider from the output to FB and GND to set V _{OUT}

PACKAGE OUTLINE

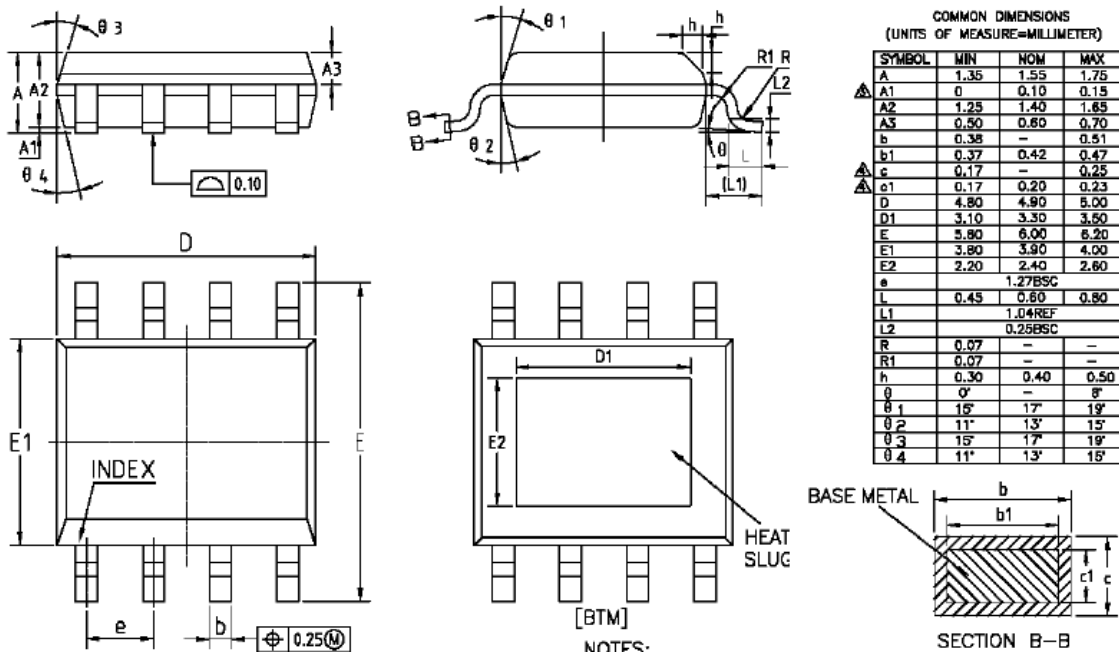

NOTES:
ALL DIMENSIONS REFER TO JEDEC STANDARD MS-012 AA
DO NOT INCLUDE MOLD FLASH OR PROTRUSIONS.