

40V Input, 150mA Linear Regulator

DESCRIPTION

ETA5095 is a linear regulator features wide input range, high power-supply rejection ratio(PSRR) and low noise. The device provides fixed output voltages of 3.3V and 5V. The output voltage is also adjustable. It can be programmed by a resistor divider from 1.5V to 24V.

The device also includes short circuit protection, over voltage protection and thermal shutdown. The shutdown current of ETA5095 is as low as 2uA.

Therefore, ETA5095 is an ideal power supply for power delivery, personal digital assistants, low power battery-powered applications.

ETA5095 is available in SOT23-5 and SOT89-3

FEATURES

- ◆ Wide Input Voltage Range: From 6V to 40V
- ◆ Programmable Output Voltage: From 1.5V to 24V
- ◆ Up to 150mA Output Current
- ◆ Very Accurate Output Voltage: 3% Over Temperature and Input Voltage
- ◆ Accurate EN threshold for setting external UVLO
- ◆ High PSRR, 60dB
- ◆ Integrated Thermal and Current Limit

APPLICATIONS

- ◆ Space-Sensitive Applications
- ◆ Battery-Powered Equipment
- ◆ Cordless and Mobile Phones
- ◆ Industrial and Medical Equipment
- ◆ Portable Equipment

TYPICAL APPLICATION

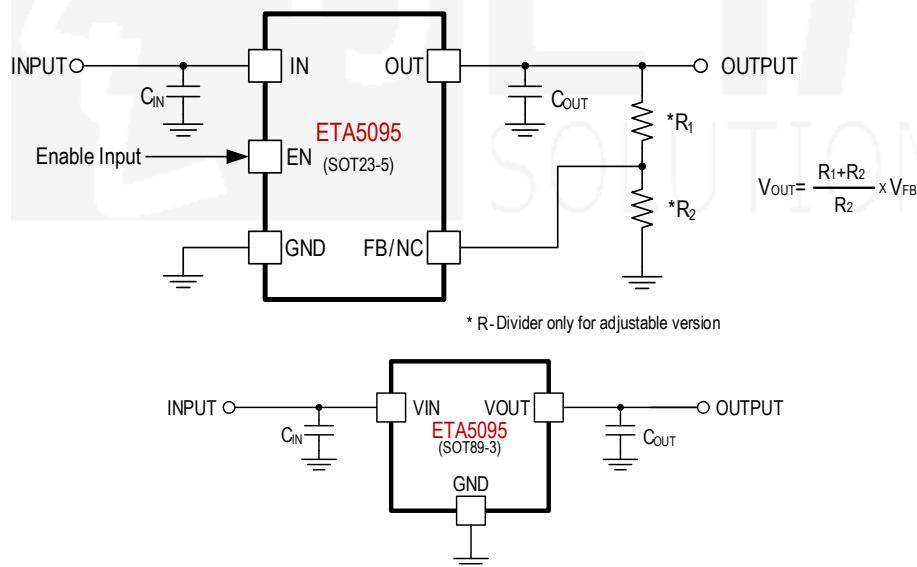

ORDERING

INFORMATION

PART No.	PACKAGE	TOP MARK	Pcs/Reel
ETA5095S2F	SOT23-5	JFYW	3000
ETA5095V33S2F	SOT23-5	JPYW	3000
ETA5095V50S2F	SOT23-5	JZYW	3000
ETA5095V33S8D	SOT89-3	JPYW	1000
ETA5095V50S8D	SOT89-3	JZYW	1000

PIN CONFIGURATION

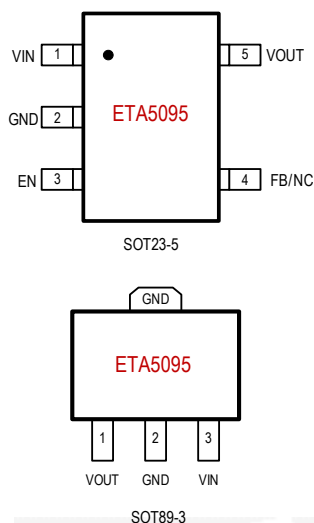

Figure 1: Pin Configuration

ABSOLUTE MAXIMUM RATINGS

(Note: Exceeding these limits may damage the device. Exposure to absolute maximum rating conditions for long periods may affect device reliability.)

VIN to GND Voltage	-0.3V to 42V
VOUT to GND Voltage.....	-0.3V to 42V
EN to GND Voltage	-0.3V to 42V
FB to GND Voltage.....	-0.3V to 6V
VOUT current	Internally limited
Operating Temperature Range	-40°C to 85°C
Storage Temperature Range	-55°C to 150°C
Thermal Resistance θ_{JC} θ_{JA}	
SOT23-5L.....	90.....180..... °C/W
SOT89-3.....	9.....52..... °C/W
Lead Temperature (Soldering, 10sec)	260°C
ESD HBM (Human Body Mode).....	2KV
ESD MM (Machine Mode).....	200V

ELECTRICAL CHARACTERISTICS

($V_{IN} = V_{OUT(TYP)} + \geq 1V$, unless otherwise specified. Typical values are at $T_A = 25^\circ C$.)

SYMBOL	PARAMETER	TEST CONDITIONS	MIN	TYP	MAX	UNIT
V_{IN_RANGE}	Input Supply Range		6		40	V
UVLO	Under Voltage Lock Output	V_{IN} Rising		6		V
	UVLO Hysteresis	V_{IN} Falling		500		mV
OVP	IN Over Voltage Protection Threshold	V_{IN} Rising		40.5	44	V
	OVP Hysteresis	V_{IN} Falling		1		V
I_Q	Quiescent Current	EN = Floating		75	200	μA
I_{SD}	Shutdown Current	EN = 0V		2	5	μA
V_{DROP}	Dropout Voltage	$V_{OUT} = 12, I_{OUT} = 100mA$		1	1.5	V
V_{OUT_RANGE}	Output Voltage Range		1.5		24	V
V_{OUT_ACC}	Output Voltage Accuracy	$T_J = 25^\circ C$	-2		+2	%
		$-40^\circ C < T_J < 125^\circ C$	-3		+3	%
V_{FB}	FB Pin Regulation Voltage	$T_J = 25^\circ C$	1.083	1.1	1.117	V
		$-40^\circ C < T_J < 125^\circ C$	1.075	1.1	1.125	V
I_{LIM}	Output Current Limit		150			mA
I_{FB}	Foldback Current Limit	$V_{OUT} = 0V$		20		mA
V_{LOAD}	Static Load Regulation	$1mA < I_{OUT} < 150mA$		0.003		%/mA
V_{LINE}	Static Line Regulation	$V_{OUT} + 2V < V_{IN} < 40V$		0.05		%/V

SYMBOL	PARAMETER	TEST CONDITIONS	MIN	TYP	MAX	UNIT
Noise	Output Noise Voltage	$V_{OUT} = 3.3V$, integrated noise (10hz – 20khz)		250		μV_{RMS}
PSRR	Power Supply Rejection Ratio	Frequency = 1kHz, no output cap		60		dB
		Frequency = 10kHz, no output cap		50		dB
T_{SHUT}	Thermal Shutdown Threshold			150		°C
	Thermal Shutdown Threshold Hysteresis			30		
T_{EN}	Enable Delay Time			300		μs
V_{HI}	Enable Input Logic High	EN Pin Voltage Rising	1.1	1.18	1.26	V
V_{LO}	Enable Input Logic Low	EN Pin Voltage Falling		1		V
I_{EN}	Enable Pin Input Current	$V_{EN} = 24V$			2	μA

PIN DESCRIPTION

SOT23-5 PIN #	SOT89-3 PIN#	PIN NAME	DESCRIPTION
1	1	IN	Input Supply Pin
2	2	GND	Ground Pin
3	NA	EN	Enable Pin. Drive it high to enable IC, drive it low to disable
4	NA	FB/NC	Feedback pin for output voltage configuration, FB only for adjustable voltage version, fixed voltage version internal no connection
5	3	OUT	Output of regulator

FUNCTIONAL BLOCK DIAGRAM

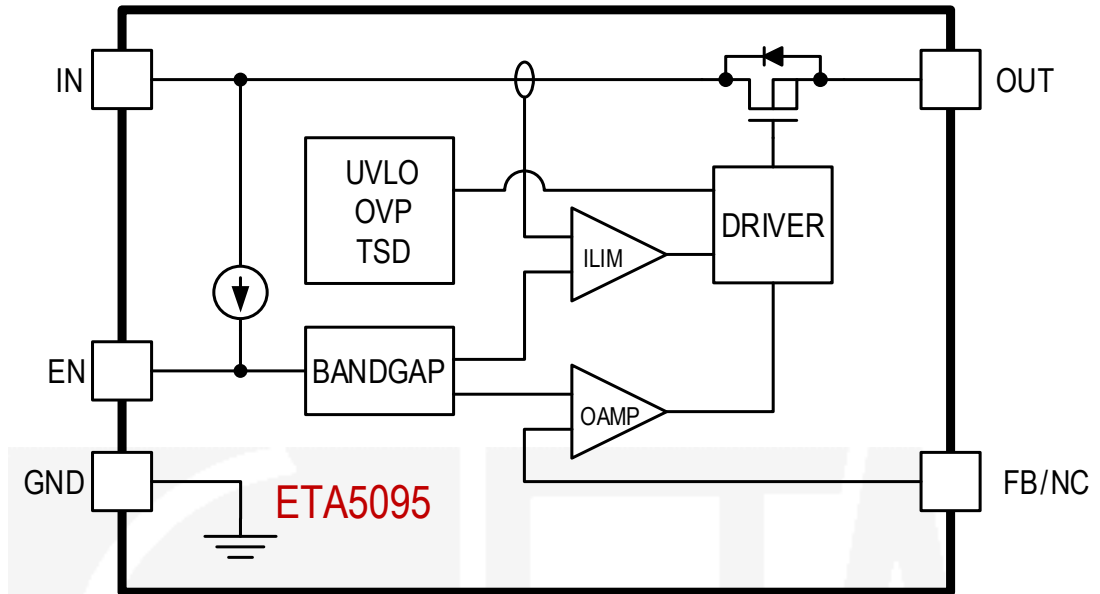
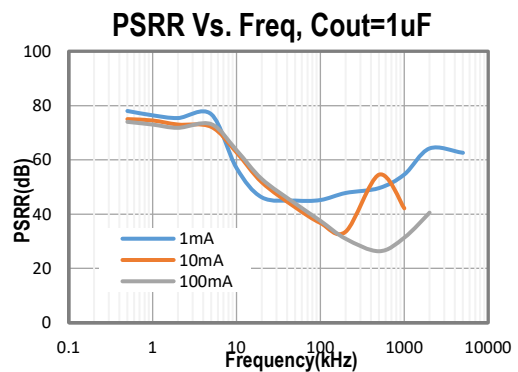
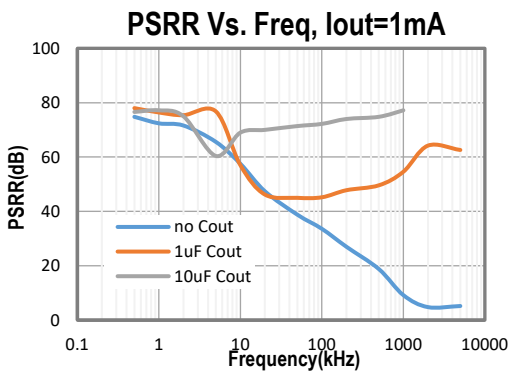
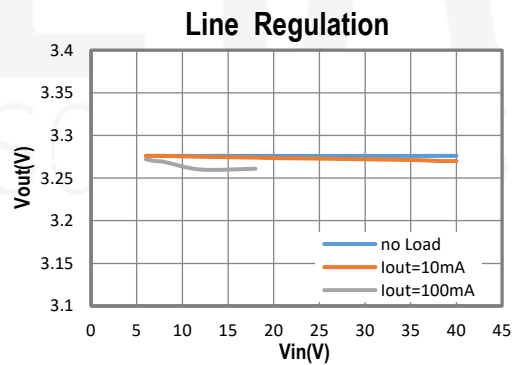
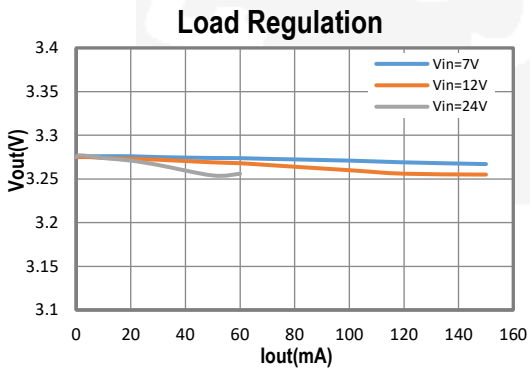
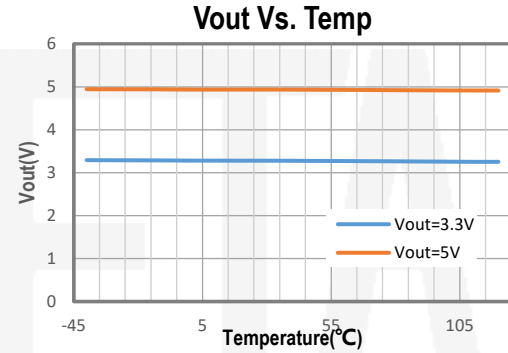
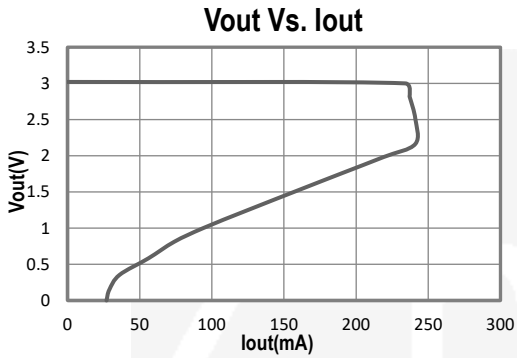
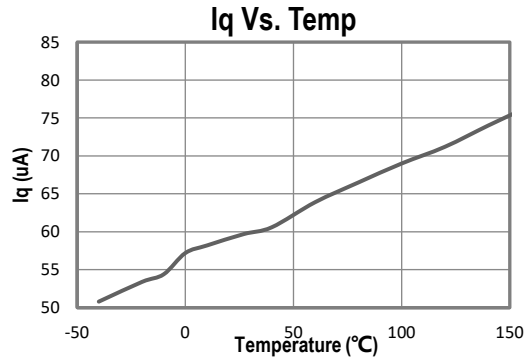
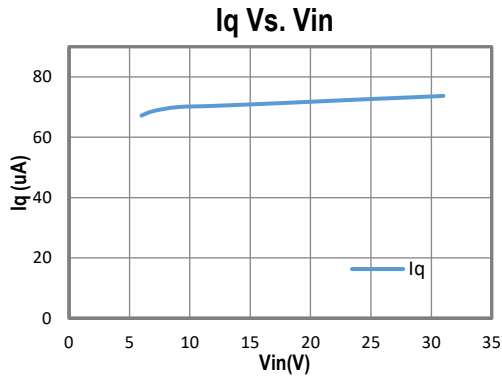

Figure 2: Functional Block Diagram

TYPICAL PERFORMANCE CHARACTERISTICS

(TA=25°C, VIN = 12V if not specified)



TYPICAL PERFORMANCE CHARACTERISTICS CONT'D

(TA=25°C, V_{IN} = 12V if not specified)

Output Load Transient without any Capacitor,
V_{IN} = 12V, V_{OUT} = 3.3V

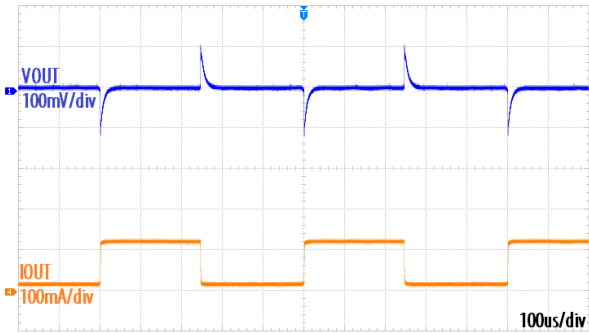

Output Load Transient with C_{OUT} = 100nF,
V_{IN} = 12V, V_{OUT} = 3.3V

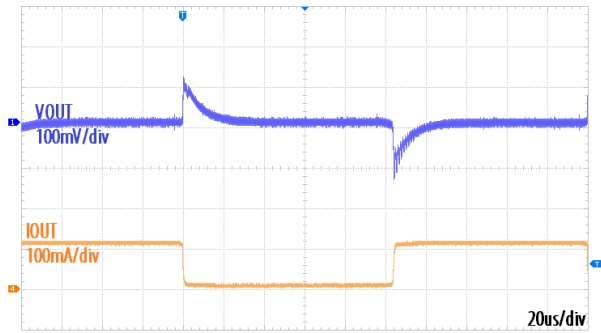

Output Load Transient without any Capacitor,
V_{IN} = 24V, V_{OUT} = 12V

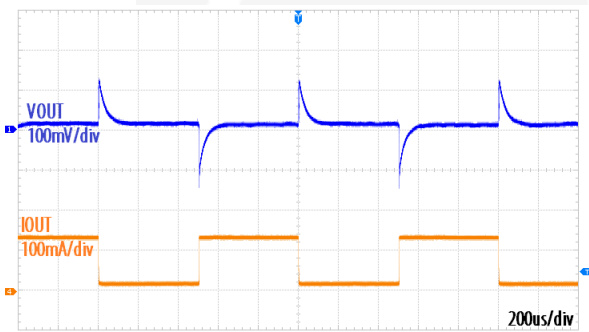

Output Load Transient with C_{OUT} = 100nF,
V_{IN} = 24V, V_{OUT} = 12V

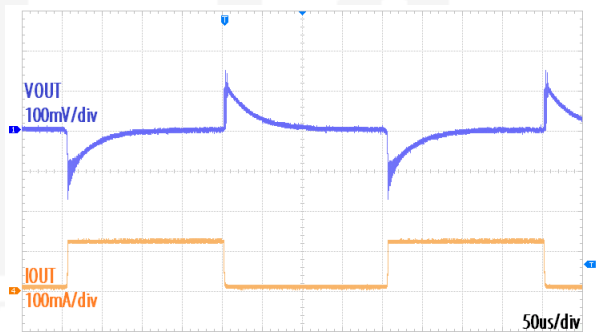

Line Transient Without Output Capacitor,
V_{OUT} = 3.3V, I_{OUT} = 10mA

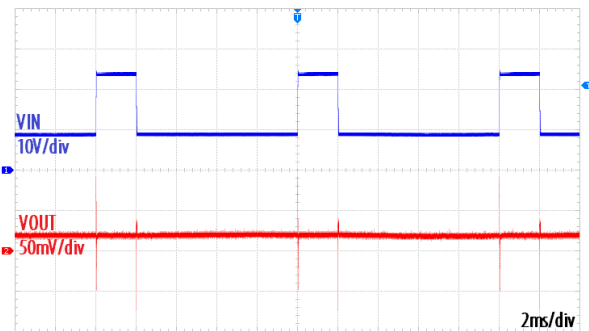

Line Transient Without Output Capacitor,
V_{OUT} = 12V, I_{OUT} = 12mA

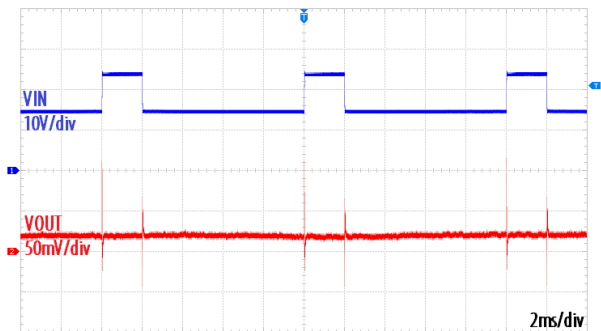

FUNCTIONAL DESCRIPTION

General Description

The main feature of the ETA5095 is its capability to operate with wide input range and with small input and output capacitors. ETA5095 use a new architecture of LDO to have sufficient phase margin over all positions of the output capacitor pole. It also includes protection features like input over voltage protection, short circuit protection and thermal shutdown.

Enable Sequence

ETA5095 is enabled when all following conditions occur:

- ◆ EN pin voltage is greater than a logic high,
- ◆ $UVLO < V_{IN} < OVP$,
- ◆ Junction temperature is less than Thermal Shutdown,

Once all above conditions are occurred, ETA5095 will be enabled after 500us. In case any of above conditions is not correct, ETA5095 will be in shutdown mode. EN pin is internally pulled up to a Logic High.

Output Current Limit and Foldback Current Limit

ETA5095 guarantees 150mA output current for all output voltage configuration, so it is designed with 250mA (typically). ETA5095 current limit is reduced when output voltage is less than 75% of the configuration. The reduction is linearity and finish when output voltage is at 25% when the limit is only 20mA (typically) left. This feature will make sure ETA5095 will always do its start-up successfully with any load less than maximum loading.

Over-Temperature Protection

Thermal protection disables the output when the junction temperature rises to approximately 150°C, allowing the device to cool down. When the junction temperature cools to approximately 120°C, the output circuitry is again enabled. Depending on power dissipation, thermal resistance, and ambient temperature, the thermal protection circuit may cycle on and off. This cycling limits regulator dissipation, protecting the device from damage as a result of overheating.

APPLICATION INFORMATION

Capacitor Selection

ETA5095 does not require high capacitors at both VIN and VOUT pins for stability. Using 100nF capacitor at VOUT will be suitable for the output voltage up to 8V, with any load type. Using 220nF capacitor at VOUT will be suitable for the output voltage up to 14V, with any load type.

External Output Voltage Setting

In external Output Voltage Setting Version selected, the ETA5095 regulator is programmed using an external resistor divider. The output voltage is calculated using below equation.

$$V_{OUT} = V_{FB} \times \left(1 + \frac{R_1}{R_2} \right)$$

Resistors R₁ and R₂ should be chosen for approximately 40µA divider current. Lower value resistors can be used for improved noise performance, but the solution consumes more power. Higher resistors values can cause accuracy issues. The recommended design procedure is to choose R₂ = 20kΩ to set the divider current at 40µA, then R₁ is calculated using below equation.

$$R_1 = \left(\frac{V_{OUT}}{V_{FB}} - 1 \right) \times R_2$$

PACKAGE OUTLINE

Package: SOT23-5

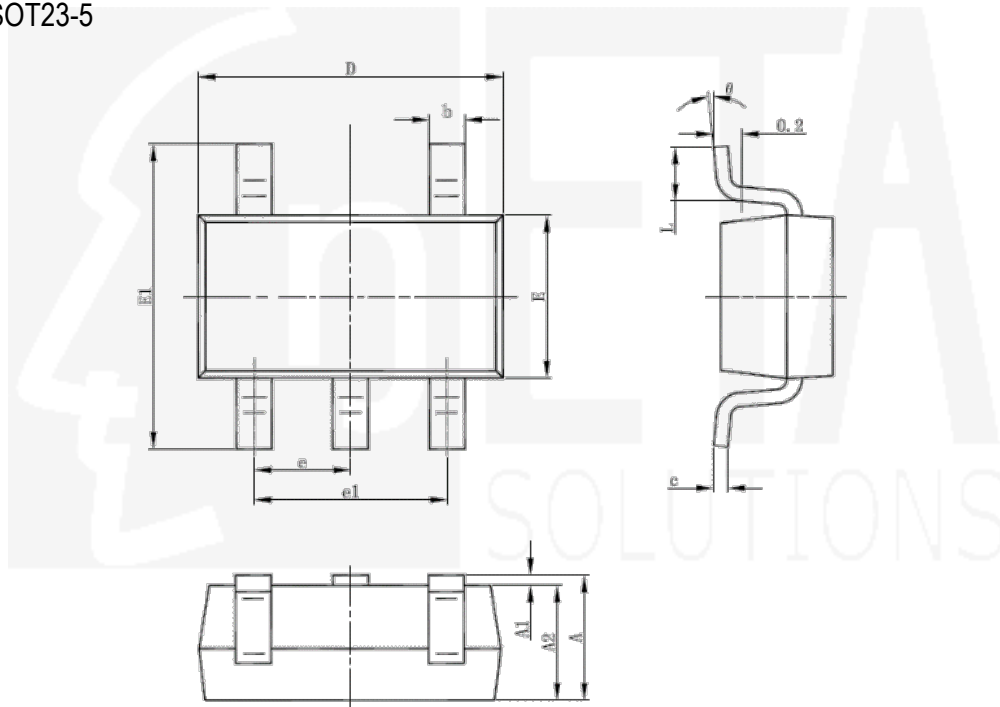

Symbol	Dimensions In Millimeters		Dimensions In Inches	
	Min	Max	Min	Max
A	1.050	1.250	0.041	0.049
A1	0.000	0.100	0.000	0.004
A2	1.050	1.150	0.041	0.045
b	0.300	0.500	0.012	0.020
c	0.100	0.200	0.004	0.008
D	2.820	3.020	0.111	0.119
E	1.500	1.700	0.059	0.067
E1	2.650	2.950	0.104	0.116
e	0.950(BSC)		0.037(BSC)	
e1	1.800	2.000	0.071	0.079
L	0.300	0.600	0.012	0.024
θ	0°	8°	0°	8°

PACKAGE OUTLINE(Con't)

Package: SOT89-3

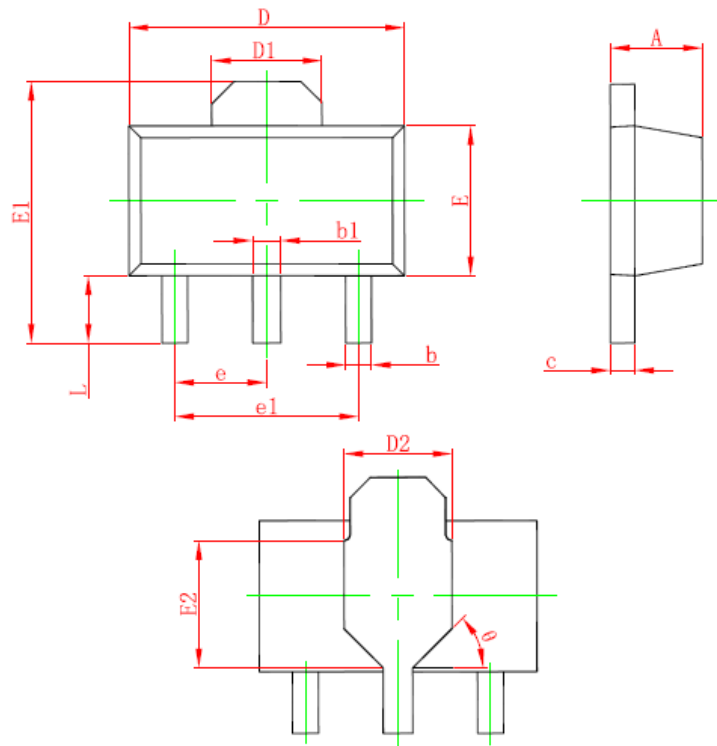

Symbol	Dimensions In Millimeters		Dimensions In Inches	
	Min.	Max.	Min.	Max.
A	1.400	1.600	0.055	0.063
b	0.320	0.520	0.013	0.020
b1	0.400	0.580	0.016	0.023
c	0.350	0.440	0.014	0.017
D	4.400	4.600	0.173	0.181
D1	1.550 REF.		0.061 REF.	
D2	1.750 REF.		0.069 REF.	
E	2.300	2.600	0.091	0.102
E1	3.940	4.250	0.155	0.167
E2	1.900 REF.		0.075 REF.	
e	1.500 TYP.		0.060 TYP.	
e1	3.000 TYP.		0.118 TYP.	
L	0.900	1.200	0.035	0.047
θ	45°		45°	