

# 1MHz High Current High Efficiency Synchronous Step-Up Converter in ESOP8

## DESCRIPTION

ETA1096 is an ETA Solutions' high efficiency, high frequency synchronous Step-Up converter, capable of delivering output current up to 3A at a 5V output from a 3.6V input. With a low  $R_{dson}$  Power MOS and a built-in synchronous rectifier, its efficiency can be as high as 93% at a 5V/2.1A load. This greatly minimizes power dissipation and reduces heat on the IC, making it ideal for applications that require small board space and have stringent temperature constraints, such as power banks and mobile devices. ETA1096 also incorporates ETA Solutions' True-Shutoff<sup>®</sup> technology that protects against overload and short-circuit conditions. With 1MHz switching frequency, small external input and output capacitors and inductor can be used.

All of these features are integrated in an economic ESOP8 package, and peripheral component count is minimal.

## FEATURES

- ◆ Up to 97% Energy Converting Efficiency
- ◆ Up to 3A output current at 5V output, 3.6V input
- ◆ Externally adjustable output voltage
- ◆ True Shut off during shutdown and output short-circuit protection
- ◆ Thermal Shutdown
- ◆ ESOP8 package

## APPLICATIONS

- ◆ 3G/4G PCI-e module
- ◆ Power Bank
- ◆ Mobile 3G/4G Mi-Fi

## TYPICAL APPLICATION

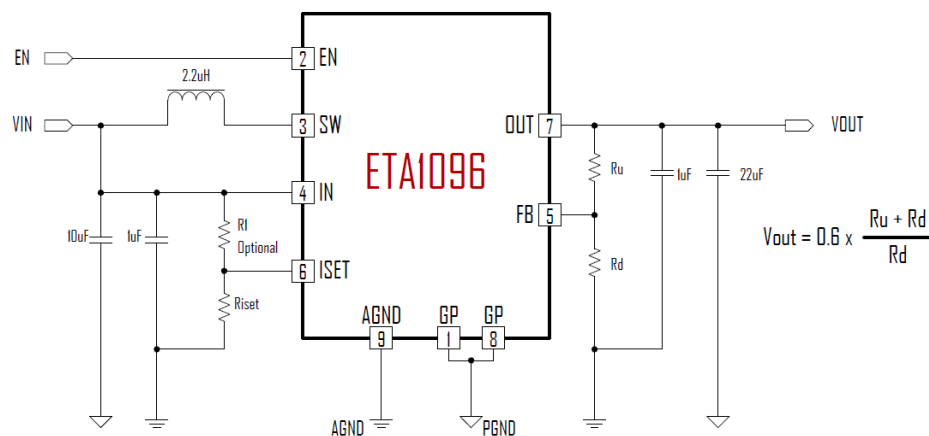

Riset is for inductor peak current limit setting:  $I_{peak} = 180K/Riset$  (A)  
 RI is optional, for output current limit less sensitive to  $V_{in}$  voltage.

## ORDERING INFORMATION

PART No.	PACKAGE	TOP MARK	Pcs/Reel
ETA1096E8A	ESOP8	ETA1096 YWW2L	4000

## PIN CONFIGURATION

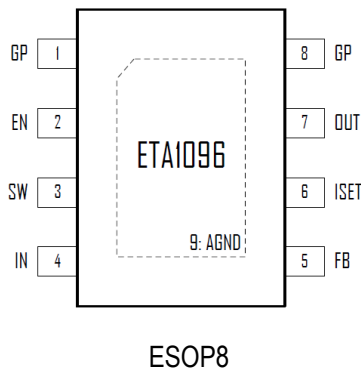

## ABSOLUTE MAXIMUM RATINGS

(Note: Exceeding these limits may damage the device. Exposure to absolute maximum rating conditions for long periods may affect device reliability.)

All Pins Voltage.....	-0.3V to 5.5V
Operating Temperature Range .....	-40°C to 85°
Storage Temperature Range .....	-55°C to 150°C
Thermal Resistance $\theta_{JC}$ $\theta_{JA}$	
ESOP8.....	10.....50 .....°C/W
Lead Temperature (Soldering, 10ssec) .....	260°C
ESD HBM (Human Body Mode) .....	2KV
ESD MM (Machine Mode) .....	200V

## ELECTRICAL CHARACTERISTICS

( $V_{IN}=3.3V$ ,  $V_{OUT}=3.8V$ ,  $AGND=PGND$ , unless otherwise specified. Typical values are at  $T_A = 25^\circ C$ .)

PARAMETER	CONDITIONS	MIN	TYP	MAX	UNITS
Quiescent Current	EN=IN, No load, Not switching		50	80	$\mu A$
Shutdown Supply Current at $V_{IN}$	$V_{EN} = GND$		0.5	5	$\mu A$
$V_{IN}$ UVLO Voltage, $V_{UVLO}$			1.8		V
$V_{IN}$ UVLO hysteresis			0.3		V
Feedback Voltage	$V_{OUT} = 2.1$ to $5V$	0.588	0.6	0.612	V
FB Leakage Current			0		nA
Output Over Voltage Protection	Hysteresis=500mV		6		V
NMOS Switch On Resistance			40		m $\Omega$
PMOS Switch On Resistance			55		m $\Omega$
SW Leakage Current	$V_{OUT}=5V, V_{SW}=0$ or $5V, V_{EN}=GND$			10	$\mu A$
Start-up Current Limit			2.5		A
Switching Frequency		0.7	1	1.3	MHz
Short Circuit Hiccup time	ON		3.75		ms
	OFF		75		ms
Inductor Peak Current Limit	$R_{ISET}=51k\Omega$	2.5	3.5	4.5	A
	$R_{ISET}=30k\Omega$		6		A
EN Input Current	$V_{EN}=3V$		1.5		$\mu A$
EN logic high voltage		1.6			V
EN logic low voltage				0.6	V
Thermal Shutdown	Rising, Hysteresis=20°C		150		°C

## PIN DESCRIPTION

PIN #	NAME	DESCRIPTION
1, 8	GP	Power ground pin.
2	EN	Enable pin for the IC. Drive this pin high to enable the IC, low or floating to disable.
3	SW	Switching node of the Switching Regulator. Connect a 1uH to 2.2uH inductor between IN and SW pin.
4	IN	Input pin. Bypass IN to GND with a 10uF or greater ceramic capacitor.
5	FB	Feedback Input. Connect an external resistor divider from the output to FB and GND to set $V_{OUT}$ , with the equation: $V_{out} = 0.6 \times (R_u + R_d) / R_d$
6	ISET	Programmable peak-current-limit control. Connect an external resistor (Riset) between ISET and AGND to set the peak NMOS current-limit threshold. The current-limit threshold may be adjusted from 0.6A to 5.0A, And if follows following equation: $I_{peak} = (180 / R_{iset}) * 1000 \text{ (A)}$
7	OUT	Output pin. Bypass with a 22uF or larger ceramic capacitor closely between this pin and ground.
9	AGND	Analog ground pin. AGND is internally connected to the analog ground of the control circuitry.

## TYPICAL CHARACTERISTICS

(Typical values are at  $T_A = 25^\circ\text{C}$  unless otherwise specified.)

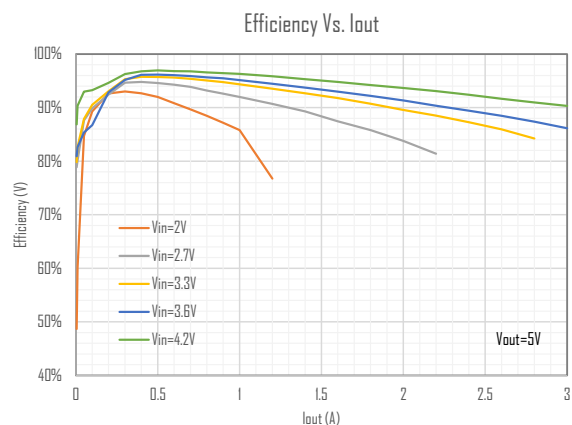
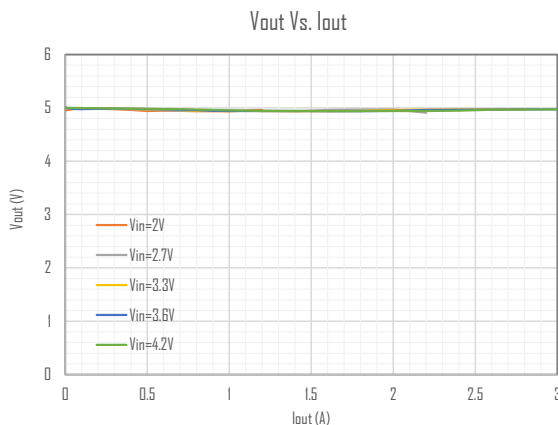

## APPLICATION INFORMATION

### Loop Operation

The ETA1096 is a wide input range, high-efficiency, DC/DC step up switching regulator, integrated with a 40mΩ Low Side Main MOSFET and 55mΩ synchronous MOSFET. It uses a PWM current-mode control scheme. An error amplifier integrates error between the FB signal and the internal reference voltage. The output of the integrator is then compared to the sum of a current-sense signal and the slope compensation ramp. This operation generates a PWM signal that modulates the duty cycle of the power MOSFETs to achieve regulation for output voltage.

The output voltage is adjustable by external resistor. The peak current of the NMOS switch is also sensed to limit the maximum current flowing through the switch and the inductor. The maximum peak current limit is set to 6A and can be tuned by external resistor. An internal temperature sensor prevents the device from getting overheated in case of excessive power dissipation.

### Light Load Operation

Traditionally, a fixed constant frequency PWM DC/DC regulator always switches even when the output load is small. When energy is shuffling back and forth through the power MOSFETs, power is lost due to the finite RDSOns of the MOSFETs and parasitic capacitances. At light load, this loss is prominent and efficiency is therefore very low. ETA1096 employs a proprietary control scheme that improves efficiency in this situation by enabling the device into a power saving mode during light load, thereby extending the range of high efficiency operation.

### Short-Circuit Protection

Unlike most step-up converters, the ETA1096 allows for short circuits on the output. In the event of a short circuit, the device first turns off the NMOS when the sensed current reaches the current limit. After  $V_{OUT}$  drops below  $V_{IN}$  the device then enters a linear charge period with the current limited same as with the start-up period. In addition, the thermal shutdown circuits disable switching if the die temperature rises above 150°C.

### Down Mode ( $V_{IN} > V_{OUT}$ ) Operation

The ETA1096 will continue to supply the output voltage even when the input voltage exceeds the output voltage. Since the PMOS no longer acts as a low-impedance switch in this mode, power dissipation increases within the IC to cause a sharp drop in efficiency. Limit the maximum output current to maintain an acceptable junction temperature.

### Output Voltage Setting

The ETA1096 has an internal reference voltage set at 0.6V as a feedback voltage for setting external output voltage. By connecting a resistor (R1) between Vout and FB, and a resistor (R2) between FB and GND, one can set the output voltage by following equation, and please make sure the output voltage is set higher than the maximum input voltage

$$V_{out} = 0.6 \times (R1+R2)/R2$$

## Switching Peak Current Limit Setting

The ETA1096 allows one to set the switching peak current by external resistor (Riset). The switching peak current limit is more like an input current limit given a fixed inductor value. If one needs an output current limit, both input voltage, output voltage, and efficiency have to be taken into account to calculate the input current. The switching peak current setting follows the equation:  $I_{peak} = (180/Riset) * 1000$  (A)

## Output Current Limit Setting

As mentioned above, inductor current peak limit just keeps input current constant, the output current limit of the Boost system increases with the input voltage at given output voltage. But in some circumstances, a constant output current limit is more favorable. And then, connecting R1 between IN and ISET pin may help the output current constant, because when input voltage increases, a current from IN to ISET pin through R1 will compensate part of current that flow out of ISET pins, which is the current source to determine the inductor current peak. In shorts, with the existence of R1, inductor current limit will decrease when input voltage increases and thus keep the output current limit less sensitive to input voltage, and almost a constant current limit can be achieved by carefully selecting the value of R1 and Riset.

In the application circuit shown below, one can find the R1 which is indicated as “optional”, and only needed for setting output current limit irrelative to input voltage.

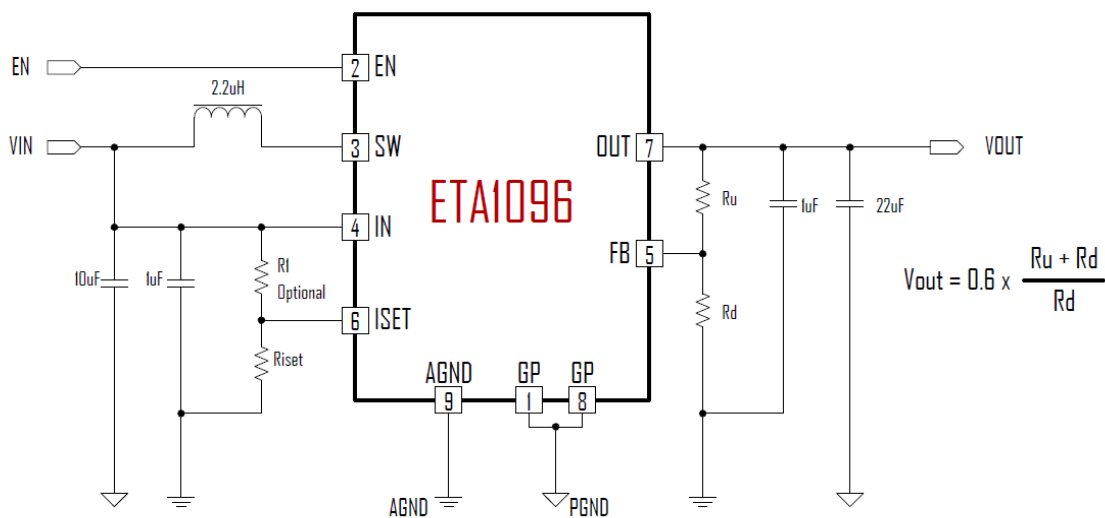

Riset is for inductor peak current limit setting:  $I_{peak} = 180K/Riset$  (A)

R1 is optional, for output current limit less sensitive to Vin voltage.

By setting R1 160Kohm and Riset 24Kohm, an almost constant current limit (2.2A) is achieved with input voltage from 3.0V to 4.2V, which is shown by following charts. The output current limit is measured by forcing output voltage at 4.75V while the ETA1096 is set to have normal output voltage at 5V.

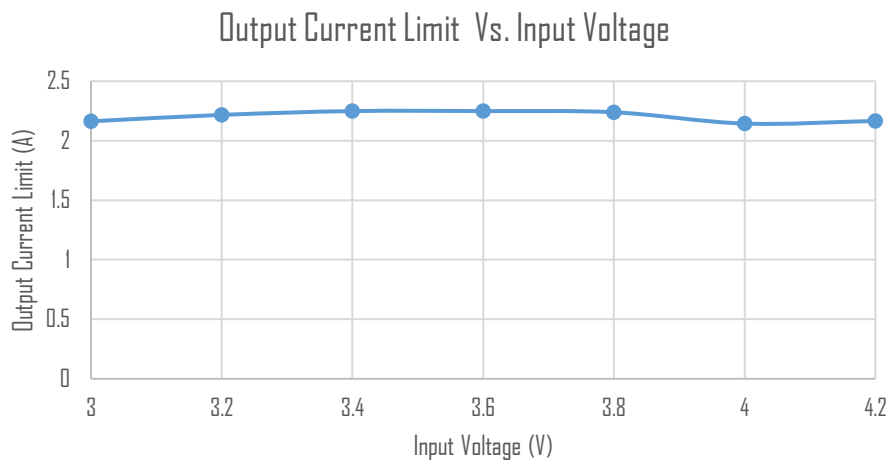

Please contact ETA engineers and let them know the desired constant output current limit, R1 and Riset will be soon calculated for customers.

## THERMAL CONSIDERATIONS

As the ETA1096 has a power MOSFET with internal current limit up to 6A, heat dissipation is always needed to be considered when designing the PCB for such high-power step-up converter. ETA1096 employs a package of ESOP8 with only 10°C/W thermal resistance from chip to its thermal pad. So it is crucial for one to lay a large area of copper (in most case, it is the large ground plane), directly contacting the thermal pad of the chip through more than 2 large vias from bottom, to spread the heat away to the ambient environment as fast as possible.

A thicker copper foil is always recommended to help the heat dissipation, so a PCB with 2oz copper thickness is a much better choice than that of 1oz copper.

## BLOCK DIAGRAM

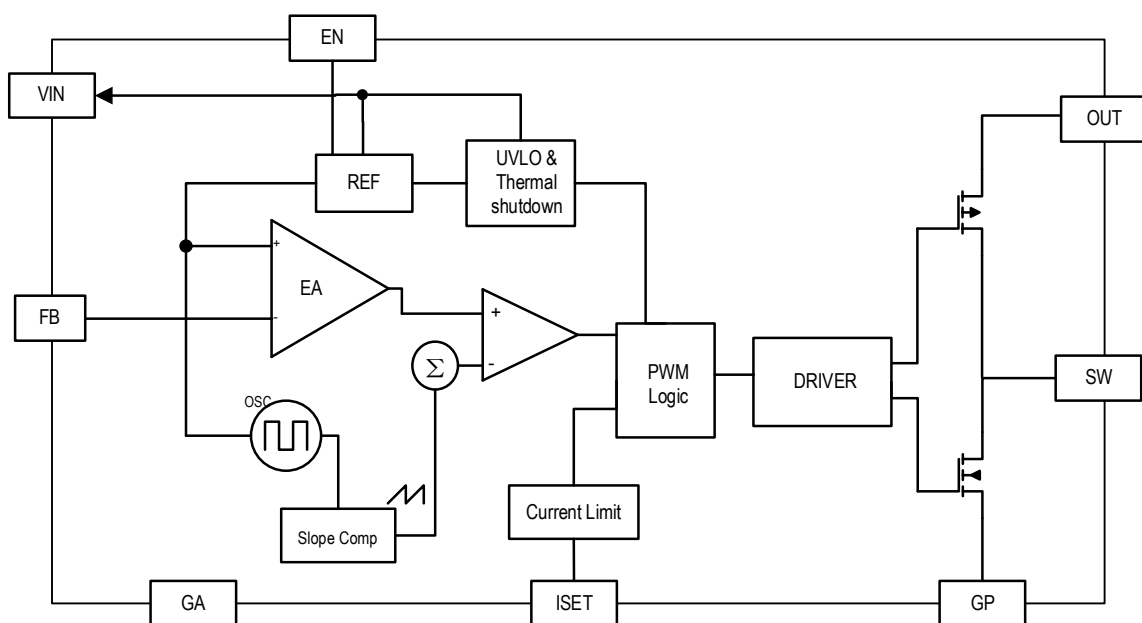

## PCB GUIDELINES

A typical ETA1096 demo board is shown below. Because the ETA1096 has Vout pins on opposite sides of the chip, please always place 2 output capacitors (CO1, and CO2) closest to the Vout pins (pin7) and GP (pin8 and pin1). As one can see on the demo board, There are many peripheral devices is not necessary for real application, such as Csw, FB (ferrite-bead), and many small capacitors along the power trace. These are the options for fine-tuning the EMI characteristics of the demo board.

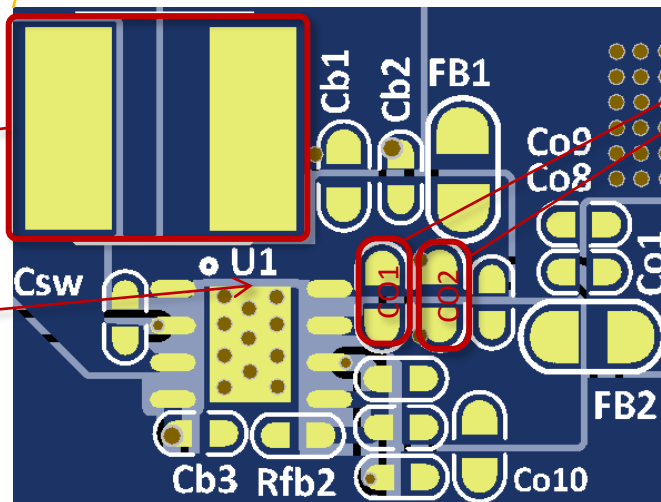
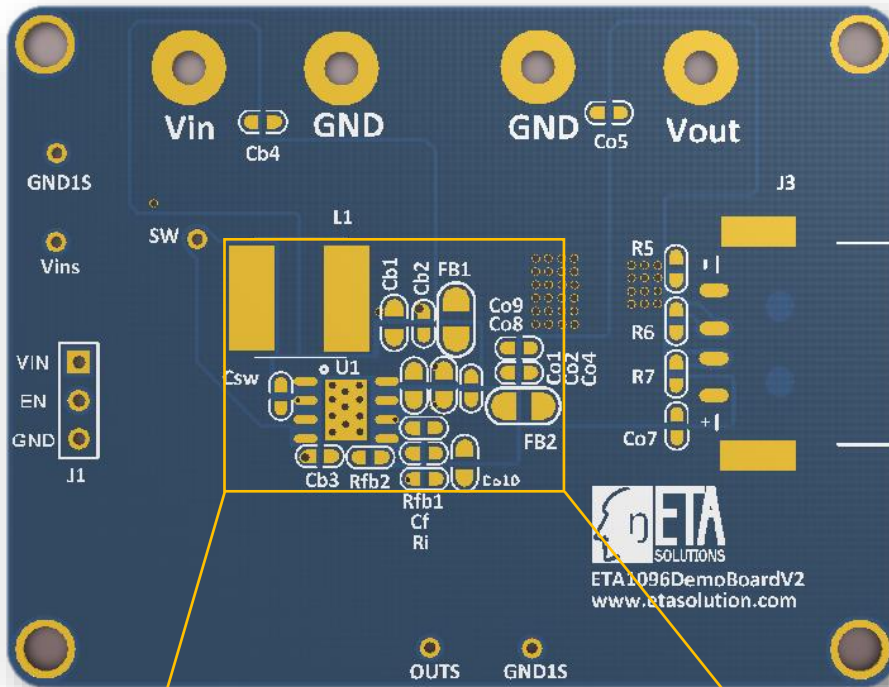

Inductor

To place the 2 output capacitors just next to ETA1096, with shortest path to OUT and GP pins

Please **DONOT** connect AGND and PGND here, to avoid PGND noise affecting the clean analog ground.

## PACKAGE OUTLINE

Package: ESOP8

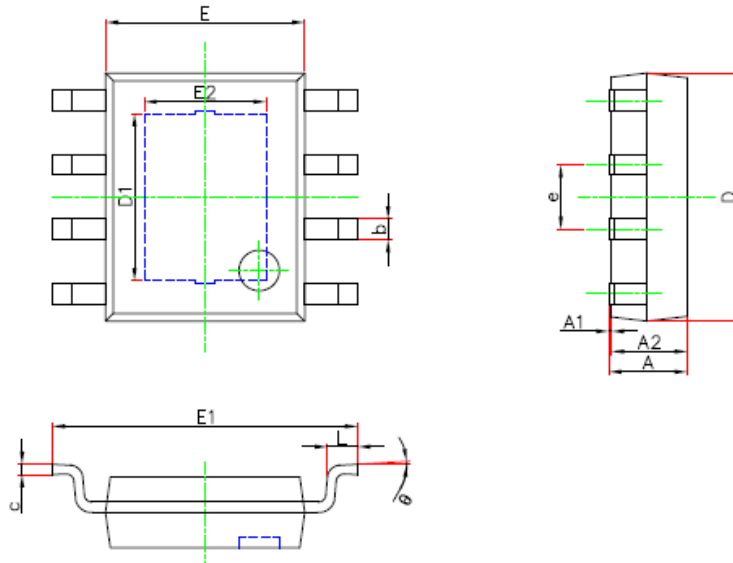

Symbol	Dimensions In Millimeters		Dimensions In Inches	
	Min.	Max.	Min.	Max.
A	1.300	1.700	0.051	0.067
A1	0.000	0.100	0.000	0.004
A2	1.350	1.550	0.053	0.061
b	0.330	0.510	0.013	0.020
c	0.170	0.250	0.007	0.010
D	4.700	5.100	0.185	0.201
D1	3.202	3.402	0.126	0.134
E	3.800	4.000	0.150	0.157
E1	5.800	6.200	0.228	0.244
E2	2.313	2.513	0.091	0.099
e	1.270(BSC)		0.050(BSC)	
L	0.400	1.270	0.016	0.050
θ	0°	8°	0°	8°

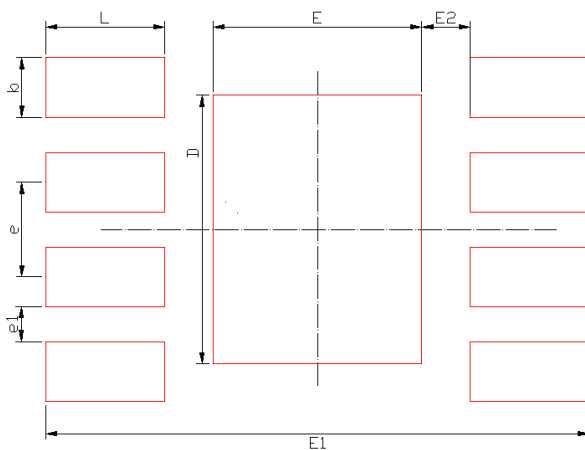

Dimensions	Value (in mm)
D	3.6
E	2.8
E1	7.3
E2	0.65
b	0.8
e	1.27
e1	0.47
L	1.6

RECOMMENDED LAND PATTERN



## TAPE AND REEL INFORMATION

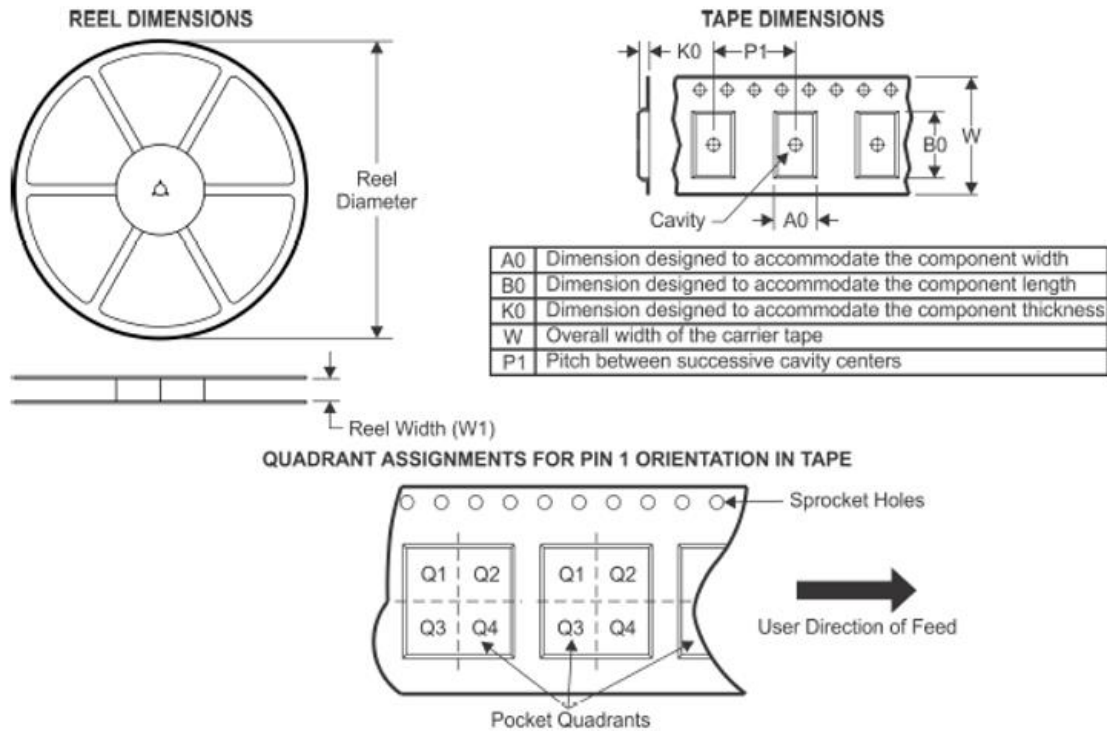

Device	Package Type	Pins	SPQ	Reel Diameter (mm)	Reel Width W1 (mm)	A0 (mm)	B0 (mm)	K0 (mm)	P1 (mm)	W (mm)	Pin1 Quadrant
ETA1096E8A	ESOP8	8	4000	330	12.7	6.6	5.4	2.05	8	12	Q1